

**Genie Industries**

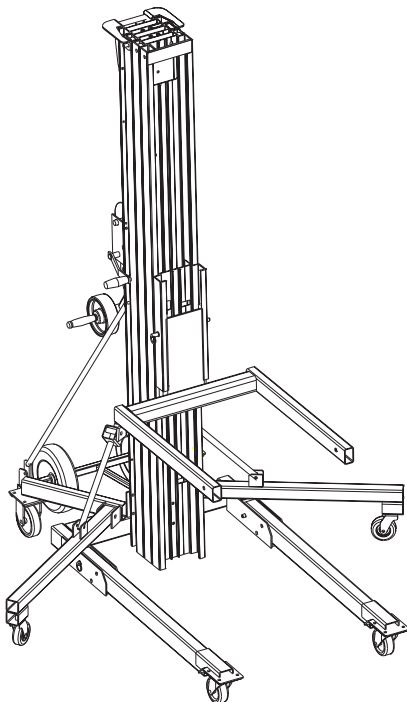

# **Genie *SUPERLIFT Contractor***

# **Parts & Service Manual**



First Edition, First Printing  
Part No. 33953



---

# Safety Rules



## Warning

Failure to obey the instructions and safety rules in this manual and the *Genie Superlift Contractor Operator's Manual* may result in death or serious injury.

Many of the hazards identified in the operating instruction manual are also safety hazards when maintenance and repair procedures are performed.

## Do Not Perform Maintenance Unless:

- ☑ You are trained and qualified to perform maintenance on this machine.
- ☑ You read, understand and obey:
  - manufacturer's instructions and safety rules
  - employer's safety rules and worksite regulations
  - applicable governmental regulations
- ☑ You have the appropriate tools, lifting equipment and a suitable workshop.

## SAFETY RULES

**Personal Safety**

Any person working on or around a machine must be aware of all known safety hazards. Personal safety and the continued safe operation of the machine should be your top priority.



Read each procedure thoroughly. This manual and the decals on the machine use signal words to identify the following:

**▲ DANGER** Indicates the presence of a hazard that **will** cause death or serious injury.

**▲ WARNING** Indicates the presence of a hazard that **may** cause death or serious injury.

**▲ CAUTION** Indicates the presence of a hazard that **will** or **may** cause serious injury or damage to the machine.

**NOTICE** Indicates special operation or maintenance information.



Be sure to wear protective eye wear and other protective clothing if the situation warrants it.



Be aware of potential crushing hazards such as moving parts, free swinging or unsecured components, and lifting or placing loads. Always wear approved steel-toed shoes.

**Workplace Safety**

Be sure to keep sparks, flames and lighted tobacco away from flammable and combustible materials like battery gases, cleaning solvents and engine fuels. Always have an approved fire extinguisher within easy reach.



Be sure that all tools and working areas are properly maintained and ready for use. Keep work surfaces clean and free of debris that could get into machine components and cause damage.



Be sure that your workshop or work area is properly ventilated and well lit.



Be sure any forklift, overhead crane or other lifting or supporting device is fully capable of supporting and stabilizing the weight to be lifted. Use only chains or straps that are in good condition and of ample capacity.



Be sure that fasteners intended for one time use (i.e., cotter pins and self-locking nuts) are not reused. These components may fail if they are used a second time.



Be sure to properly dispose of old oil or other fluids. Use an approved container. Please be environmentally safe.

# Table of Contents

---

<b>Introduction</b>	
	Important Information ..... ii
<hr/>	
<b>Section One</b>	<b>Safety Rules</b>
	General Safety Rules ..... iii
<hr/>	
<b>Section Two</b>	<b>Specifications</b>
SLC-6	..... 2 - 1
SLC-12	..... 2 - 1
SLC-18	..... 2 - 1
SLC-24	..... 2 - 1
Bolt Torque Specification	..... 2 - 2
<hr/>	
<b>Section Three</b>	<b>Scheduled Maintenance Inspections</b>
	Introduction ..... 3 - 1
Table A	..... 3 - 2
Table B	..... 3 - 2
Table C	..... 3 - 3
Maintenance Inspection Report	..... 3 - 4
<hr/>	
<b>Section Four</b>	<b>Scheduled Maintenance Procedures</b>
	Introduction ..... 4 - 1
A-1	Inspect the Operator's Manual ..... 4 - 2
A-2	Inspect the Decals and Placards ..... 4 - 2
A-3	Inspect for Damage, Loose or Missing Parts ..... 4 - 2
A-4	Check the Winch Operation ..... 4 - 3
A-5	Inspect the Columns for Damage ..... 4 - 3
A-6	Inspect the Cable and Cable Pulleys ..... 4 - 3
A-7	Check the Mast for Proper Sequencing ..... 4 - 4
A-8	Inspect the Casters and Wheels ..... 4 - 4

## Parts and Service Manual - First Edition

## TABLE OF CONTENTS

<b>Section Four</b>	<b>Scheduled Maintenance Procedures, cont.</b>	
B-1	Inspect All Welds .....	4 - 5
B-2	Clean the Columns .....	4 - 5
B-3	Inspect and Lubricate the Winch .....	4 - 5
C-1	Lubricate the Casters and Wheels .....	4 - 6
C-2	Inspect the Mast Assembly for Wear .....	4 - 6
C-3	Replace the Winch Friction Disks .....	4 - 7
C-4	Inspect the Safety Brake System - If Equipped .....	4 - 7
C-5	Inspect the Painted Surfaces.....	4 - 8
<b>Section Five</b>	<b>Troubleshooting Flow Charts</b>	
	Introduction .....	5 - 1
1	Mast Will Not Sequence Properly .....	5 - 2
2	Carriage Will Not Raise, But Winch Will Operate .....	5 - 3
3	Winch Will Not Operate .....	5 - 4
<b>Section Six</b>	<b>Repair Procedures</b>	
	Introduction .....	6 - 1
	<b>Base Assembly</b>	
1-1	How To Remove the Base .....	6 - 2
	<b>Mast Assembly</b>	
2-1	How to Disassemble the Mast Assembly .....	6 - 3
2-2	How to Replace the Lifting Cable .....	6 - 4
2-3	How to Replace a Lifting Pulley - Mast Installed .....	6 - 5
	<b>Winches</b>	
3-1	How To Disassemble the Winch .....	6 - 6

## Table of Contents

This manual is updated frequently. If you have a printed manual, you can keep it up to date by downloading new figures from the Genie website at [www.genielift.com](http://www.genielift.com). For the most up-to-date parts information, visit the Parts Lookup System on the Genie website at [www.genielift.com](http://www.genielift.com).

How to Read Your Serial Number.....	3
Parts Stocking List.....	7
How to Order Parts.....	8
Service Parts Fax Order Form.....	9

### **Electronic Version**

Click on any page number to view the figure.

#### **100 Decals**

101.1 Decals with Words (to SLC04-28240).....	10
103.1 Decals with symbols.....	12

#### **200 Base Components**

201.1 Base Components, View 1.....	14
202.1 Base Components, View 2.....	16

#### **300 Mast and Winch Components**

301.1 Mast Components, View 1.....	18
302.1 Mast Components, View 2.....	20
303.1 Mast Components, View 3.....	22
304.1 Columns, Pulleys and Cables.....	26
305.1 Winch Components - Single Speed.....	28

#### **400 Accessories**

401.1 Forks.....	30
402.1 Pipe Cradle, Load Platform and Boom Arm.....	32
403.1 Rear Wheels.....	34

#### **Indices**

Part Number Index.....	36
Part Description Index.....	37

#### **Cross References**

Parts and Service Manual - First Edition

---



This page intentionally left blank.

# Specifications

Model	SLC-6	SLC-12	SLC-18	SLC-24	
<b>Height-Stowed</b>	86 in 218 cm	86 in 218 cm	86 in 218 cm	86 in 218 cm	
<b>Width</b>	31 <sup>1</sup> / <sub>2</sub> in 80 cm	31 <sup>1</sup> / <sub>2</sub> in 80 cm	31 <sup>1</sup> / <sub>2</sub> in 80 cm	31 <sup>1</sup> / <sub>2</sub> in 80 cm	
<b>Width-stabilizers lowered (if equipped)</b>	66 in 168 cm	66 in 168 cm	66 in 168 cm	66 in 168 cm	
<b>Length-Stowed</b>	27 <sup>3</sup> / <sub>4</sub> in 70 cm	27 <sup>3</sup> / <sub>4</sub> in 70 cm	27 <sup>3</sup> / <sub>4</sub> in 70 cm	27 <sup>3</sup> / <sub>4</sub> in 70 cm	
<b>Length-Operating</b>	54 in 137 cm	58 in 147 cm	68 in 173 cm	76 in 193 cm	
<b>Ground Clearance</b>	2 in 50.8 mm	2 in 50.8 mm	2 in 50.8 mm	2 in 50.8 mm	
<b>Load Capacity at 14" (36 cm) load center</b>	650 lbs 295 kg	650 lbs 295 kg	650 lbs 295 kg	650 lbs 295 kg	
<b>Net Weight</b>	166 lbs 75 kg	204 lbs 93 kg	307 lbs 139 kg	374 lbs 170 kg	
<b>Airborne Noise Emissions by Machinery</b> Maximum sound level at normal operating workstations (A-weighted)	85 dB	85 dB	85 dB	85 dB	
<b>Load Handling Attachments</b>	<b>Length</b>	<b>Width</b>	<b>Depth</b>	<b>Net Weight</b>	
Standard Forks	28 in 71 cm	23 in 59 cm	2 <sup>1</sup> / <sub>2</sub> in 6.5 cm	26 <sup>1</sup> / <sub>2</sub> lbs 12 kg	
Adjustable Forks	27 <sup>1</sup> / <sub>2</sub> in 70 cm	11 <sup>1</sup> / <sub>2</sub> to 30 in 29 to 76 cm	2 <sup>1</sup> / <sub>2</sub> in 6.5 cm	52 <sup>1</sup> / <sub>2</sub> lbs 23.8 kg	
Boom	44 in 112 cm	3 in 8 cm	6 in 16 cm	34 <sup>1</sup> / <sub>2</sub> lbs 15.6 kg	
Pipe Cradle	27 <sup>1</sup> / <sub>2</sub> in 70 cm	24 <sup>1</sup> / <sub>2</sub> in 63 cm	6 in 11.5 cm	10 lbs 4.5 kg	
Load Platform	26 in 66 cm	23 in 58 cm	6 in 15 cm	26 lbs 12.0 kg	
Fork Extensions (each)	30 in 76 cm	2 in 5 cm	3 in 8 cm	4 <sup>1</sup> / <sub>2</sub> lbs 2 kg	
<b>Dimensions</b>	<b>SLC-6</b>	<b>SLC-12</b>	<b>SLC-18</b>	<b>SLC-24</b>	
Standard Forks	forks down	5 ft 8 in 1.72 m	11 ft 2 in 3.40 m	16 ft 9 in 5.11 m	22 ft 3 in 6.78 m
	forks up	7 ft 5 in 2.26 m	12 ft 11 in 3.94 m	18 ft 6 in 5.64 m	24 ft 0 in 7.32 m
Adjustable Forks	forks down	5 ft 8 in 1.72 m	11 ft 2 in 3.40 m	16 ft 9 in 5.11 m	22 ft 3 in 6.78 m
	forks up	7 ft 5 in 2.26 m	12 ft 11 in 3.94 m	18 ft 6 in 5.64 m	24 ft 0 in 7.32 m
Boom	6 ft 8 in 2.03 m	12 ft 2 in 3.71 m	17 ft 9 in 5.41 m	23 ft 3 in 7.09 m	



## SPECIFICATIONS

**Bolt Torque Specifications**

Size	Threads	SAE Grade 5 Bolts			SAE Grade 8 Bolts		
		Torque - Dry inch-pounds	Torque - Dry foot-pounds	Torque - Dry Newton meters	Torque - Dry inch-pounds	Torque - Dry foot-pounds	Torque - Dry Newton meters
10	24	43		5	60		7
	32	49		6	68		8
1/4	20	96		11	144		16
	28	120		14	168		19
5/16	18		17	23		25	34
	24		19	28		25	34
3/8	16		30	41		45	61
	24		35	48		50	68
7/16	14		50	68		70	95
	20		55	75		80	109
1/2	13		75	102		110	149
	20		90	122		120	163
9/16	12		110	149		150	204
	18		120	163		170	231
5/8	11		150	204		220	298
	18		170	231		240	326
3/4	10		260	353		380	515
	16		300	407		420	570
7/8	9		430	583		600	814
	14		470	637		660	895
1	8		640	868		900	1221
	12		700	949		1000	1356

Torque specifications for lubricated bolts are 25% less than dry torque specifications for each bolt size.

These bolt torque specifications are for general use only. Specification may vary depending on application of bolt.

# Scheduled Maintenance Inspections



## Observe and Obey:

- ☑ Maintenance inspections shall be completed by a person trained and qualified on the maintenance of this machine.
- ☑ Scheduled maintenance inspections shall be completed daily, quarterly and annually as specified on the maintenance inspection report.

**WARNING** Failure to properly complete each inspection when required may result in death, serious injury or substantial machine damage.

- ☑ Immediately tag and remove from service a damaged or malfunctioning machine.
- ☑ Repair any machine damage or malfunction before operating machine.
- ☑ Keep records on all inspections for three years.
- ☑ Machines that have been out of service for a period longer than 3 months must complete the quarterly inspection.

## About This Section

### Schedule

There are three types of maintenance inspections that must be performed according to a schedule—daily, quarterly and annually. To account for repeated procedures, the Maintenance Tables and the Maintenance Inspection Report have been divided into three subsections—A, B, C. Use the following chart to determine which group(s) of procedures are required to perform a scheduled inspection.

Inspection	Table or Checklist
Daily	A
Quarterly (every 150 hours or three months)	A + B
Annual	A + B + C

### Maintenance Tables

The maintenance tables contained in this section provide summary information on the specific physical requirements for each inspection.

Complete step-by-step instructions for each scheduled maintenance procedure are provided in section 4, *Scheduled Maintenance Procedures*.



### Maintenance Inspection Report

The maintenance inspection report contains checklists for each type of scheduled inspection.





Make copies of the Maintenance Inspection Report to use for each inspection. Keep records on all inspections for three years.

# Maintenance Tables

**Table A**





		Tools are required	New parts required	Dealer service suggested
A-1	Inspect the Operator's Manual			
A-2	Inspect the Decals and Placards			
A-3	Inspect for Damage, Loose or Missing Parts			
A-4	Check the Winch Operation			
A-5	Inspect the Columns for Damage			
A-6	Inspect the Cable and Cable Pulleys			
A-7	Check the Mast for Proper Sequencing			
A-8	Inspect the Casters and Wheels			

**Table B**

B-1	Inspect All Welds			
B-2	Clean the Columns			
B-3	Inspect and Lubricate the Winch			

MAINTENANCE TABLES

**Table C**

		Tools are required	New parts required	Dealer service suggested
C-1	Lubricate the Casters and Wheels			
C-2	Inspect the Mast Assembly for Wear			
C-3	Replace the Winch Friction Disks			
C-4	Inspect the Safety Brake System - If Equipped			
C-5	Inspect the Painted Surfaces			

# Maintenance Inspection Report

**Model** \_\_\_\_\_

**Serial number** \_\_\_\_\_

**Date** \_\_\_\_\_

**Machine owner** \_\_\_\_\_

**Inspected by (print)** \_\_\_\_\_

**Inspector signature** \_\_\_\_\_

**Inspector title** \_\_\_\_\_

**Inspector company** \_\_\_\_\_

**Instructions**

- Make copies of this page to use for each inspection.
- Select the appropriate checklist(s) for the type of inspection to be performed.

- Daily Inspection: A**
- Quarterly Inspection: A+B**
- Annual Inspection: A+B+C**

- Place a check in the appropriate box after each inspection procedure is completed.
- If any inspection receives an "N", remove the machine from use, repair and re-inspect it. After repair, place a check in the "R" box.

**Legend**

- Y = yes, acceptable
- N = no, unacceptable
- R = repaired

**Comments**

---

Checklist A		Y	N	R
A-1	Operator's manual			
A-2	Decals and placards			
A-3	Damage, loose or missing parts			
A-4	Check winch			
A-5	Columns			
A-6	Inspect cable and pulleys			
A-7	Check mast for proper sequencing			
A-8	Inspect casters and wheels			

Checklist B		Y	N	R
B-1	Inspect welds			
B-2	Clean columns			
B-3	Inspect and lubricate winch			

Checklist C		Y	N	R
C-1	Lubricate casters and wheels			
C-2	Mast assembly wear			
C-3	Replace winch friction disks			
C-4	Safety brake system (if equipped)			
C-5	Inspect painted surfaces			

# Scheduled Maintenance Procedures



## Observe and Obey:

- ☑ Maintenance procedures shall be completed by a person trained and qualified on the maintenance of this machine.
- ☑ Scheduled maintenance procedures shall be completed daily, quarterly (every 3 months) and annually as specified on the maintenance inspection report.

**WARNING** Failure to properly complete each inspection when required may result in death, serious injury or substantial machine damage.

- ☑ Immediately tag and remove from service a damaged or malfunctioning machine.
- ☑ Repair any machine damage or malfunction before operating machine.
- ☑ Keep records on all inspections for three years.
- ☑ Be sure the capacities of sawhorses or other supports are sufficient to withstand machine weight. See Specifications section for specific weight.
- ☑ Be sure overhead cranes or other lifting devices are of ample capacity to handle machine weight. See Specifications section for specific weight.
- ☑ Unless otherwise specified, perform each procedure with the machine in the following configuration:
  - machine positioned on a flat level surface
  - carriage fully lowered
  - casters locked
  - load handling attachment installed

## About This Section

This section contains detailed procedures for each scheduled maintenance inspection.

Each procedure includes a description, safety warnings and step-by-step instructions.

### Symbols Legend

**DANGER** Indicates the presence of a hazard that **will** cause death or serious injury.

**WARNING** Indicates the presence of a hazard that **may** cause death or serious injury.

**CAUTION** Indicates the presence of a hazard that **will** or **may** cause serious injury or damage to the machine.

**NOTICE** Indicates special operation or maintenance information.

⊙ Indicates that a specific result is expected after performing a series of steps.

# Table A Procedures

## A-1

### Inspect the Operator's Manual

Maintaining the operator's manual in good condition is essential to safe machine operation. The operator's manual is included with each machine and should be stored in the box provided on the mast. An illegible or missing manual will not provide safety and operational information necessary for a safe operating condition.

- 1 Check to make sure the operator's manual is present and complete in the storage container on the mast.
- 2 Examine the pages of the manual to be sure that they are legible and in good condition.
- 3 Always return the manual to the storage container after use.

**NOTICE** Contact your authorized Genie distributor or Genie Industries if a replacement manual is needed.

## A-2

### Inspect the Decals and Placards

Maintaining all of the safety and instructional decals and placards in good condition is essential for safe machine operation. Decals alert operators and personnel to the many possible hazards associated with using this machine. They also provide users with operation and maintenance information. An illegible decal will fail to alert personnel of a procedure or hazard and could result in unsafe operating conditions.

- 1 Refer to the decals section in the operator's manual and use the decal list and illustration to determine that all decals and placards are in place.

- 2 Inspect all decals for legibility and damage. Replace any damaged or illegible decal immediately.

**NOTICE** Contact your authorized Genie distributor or Genie Industries if replacement decals are needed.

## A-3

### Inspect for Damage , Loose or Missing Parts

Daily machine condition inspections are essential to safe machine operation and good machine performance. Failure to locate and repair damage, and discover loose or missing parts may result in an unsafe operating condition.

- 1 Inspect the entire machine for damage and improperly installed or missing parts including:

**NOTICE** Refer to Section Seven, Service Parts, for component locations.

- cable anchor
- cable and pulleys
- mast columns
- nuts, bolts and other fasteners
- load handling attachment
- winch and related components
- legs and casters
- stabilizers, latch plates and casters
- loading wheels and pull pin
- manual storage container
- dents or damage to machine
- cracks in welds or structural components
- corrosion to painted surfaces
- corrosion or oxidation to all other surfaces

TABLE A PROCEDURES

## A-4 Check the Winch Operation

Detection of damage to the winch is essential to safe machine operation. An unsafe working condition exists if the winch is damaged or not operating correctly. A daily check of the winch operation allows the inspector to identify changes in the operating condition of the winch that might indicate damage.

- 1 Visually inspect all winch components for damage.
- 2 Raise the carriage through a partial cycle and release the winch handles.
- ⊙ Result: The winch should operate smoothly, free of hesitation or binding. The carriage should not lower when the handles are released.
- 3 Fully lower the carriage.
- ⊙ Result: The winch should operate smoothly, free of hesitation or binding.

## A-5 Inspect the Columns for Damage

Detection of damage to columns is essential for safe machine operation. An unsafe working condition exists if the columns are damaged and do not operate smoothly, free of hesitation and binding. A daily check of the columns allows the inspector to identify changes in the operating condition of the mast assembly that might indicate damage.

- 1 Visually inspect the exterior of each column for the following:
  - dents, gouges or abrasions
  - bends or warping
  - excessive wear

- 2 Raise and lower all columns through a complete cycle.
- ⊙ Result: Columns should raise and lower smoothly, free of hesitation and binding.

## A-6 Inspect the Cable and Cable Pulleys

Detection of damage to cable or pulleys is essential for safe machine operation. An unsafe working condition exists if these components are damaged and do not operate smoothly. A daily check of this system allows the inspector to identify changes in the operating condition that might indicate damage.

- 1 Visually inspect the cable and components for the following:
  - frayed or broken wire strands
  - kinks in the cable
  - corrosion
  - paint or foreign materials
  - split or cracked swagged end(s)
  - cable is properly secured to the winch
  - cable is properly secured to the mast
- 2 Using proper lifting techniques, lay the machine back against a sawhorse or other suitable support and check to be sure of the following:
  - cable is on the pulleys
  - upper and lower mounting brackets are properly secured
  - no broken or damaged pulleys or pulley guards
  - no unusual or excessive pulley wear



TABLE A PROCEDURES

### **A-7 Check the Mast for Proper Sequencing**

Detection of damage to the mast is essential for safe machine operation. An unsafe working condition exists if the mast is damaged and does not sequence properly, free of hesitation and binding. A daily check of the sequencing allows the inspector to identify changes in the operating condition of the mast assembly that might indicate damage.

- 1 Raise all columns to full height with no load on the load handling attachment.
- ⊙ Result: The carriage should rise to the top of the front column section, followed in consecutive order by each column.
- 2 Lower the columns to the stowed position.
- ⊙ Result: The columns should lower in reverse order, followed by the carriage.

### **A-8 Inspect the Casters and Wheels**

Extremely dirty conditions may require that the casters and wheels be inspected and lubricated more often.

- 1 Visually inspect each caster and wheel for cuts, cracks or unusual wear.
- 2 Move the machine on a flat smooth surface and check that the casters and wheels roll smoothly, free of hesitation and binding.
- 3 Lock the base swivel casters.
- ⊙ Result: The wheels should not roll.

## Table B Procedures

### B-1 Inspect All Welds

Weld inspections are essential to safe machine operation and good machine performance. Failure to locate and repair damage may result in an unsafe operating condition.

- 1 Visually inspect the welds in the following locations:
  - winch mounting plate
  - loading wheels/steer handle
  - base
  - legs and stabilizers
  - load handling attachment(s)

### B-2 Clean the Columns

Clean columns are essential to good machine performance and safe operation. Extremely dirty conditions may require that the columns be cleaned more often.

- 1 Raise all columns to the maximum height.
- 2 Visually inspect the inner and outer channels of the columns for debris or foreign material. If necessary, use a mild cleaning solvent to clean the columns.

**WARNING** This procedure will require the use of additional access equipment. Do not place ladders or scaffold on or against any part of the machine. Performing this procedure without the proper skills and tools may result in death or serious injury. Dealer service is strongly recommended.

**CAUTION** Do not apply any lubrication to the columns.

### B-3 Inspect and Lubricate the Winch

Maintaining the winch is essential to good machine performance and safe operation. An unsafe working condition exists if the winch has excessive wear and/or does not operate smoothly, free of hesitation and binding.

- 1 Carefully lubricate the following areas with automotive grease:
  - the cable drum gear
  - the teeth on the pinion gear that meshes with the cable drum gear
  - the threads on the pinion shaft, under the pinion gear

**NOTICE** Do not apply grease to brake friction disks or ratchet gear.

- 2 Carefully lubricate with 30W oil both pivot points on each ratchet pawl.
- 3 Inspect the friction disks for excessive wear. Replace if pad is less than  $\frac{1}{16}$  inch (1.5 mm) thick.
- 4 Inspect pinion shaft bushings for excessive wear. Replace if wall thickness of bushing is less than  $\frac{1}{8}$  inch (3.1 mm).
- 5 Lubricate the frame drum spacer. Tighten the drum bolt to 20 ft-lbs (27 Nm). Do not overtighten.

## Table C Procedures

### C-1 Lubricate the Casters and Wheels

Extremely dirty conditions may require that the casters and wheels be inspected and lubricated more often.

- 1 Visually inspect each caster and wheel for cuts, cracks or unusual wear.
- 2 Move the machine on a flat smooth surface and check that the casters and wheels roll smoothly, free of hesitation and binding.
- 3 Pump grease into the caster or wheel until it can be seen coming out of the bearing gap.

<b>Grease Type</b>	Lithium-based
--------------------	---------------

### C-2 Inspect the Mast Assembly for Wear

Detection of excessive or unusual wear in the mast assembly is essential for safe machine operation. An unsafe working condition exists if the mast assembly has excessive wear and/or does not operate smoothly, free of hesitation and binding.

- 1 Attach an overhead crane or similar lifting device to the lifting bracket on the mast. Rotate the carriage hold down bar over the carriage.
- 2 Lift the machine slightly and then guide it over onto an appropriate support. The mast assembly should be level with the carriage up.

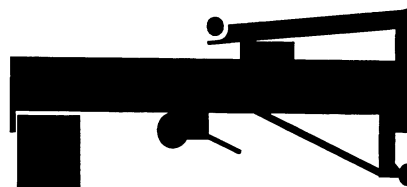

**AWARNING** Crushing hazard. The machine will fall unless it is properly supported with the overhead crane.

- 3 Visually inspect the top of each column for clearance between the roller wheel and the adjacent column surface.
- ⊙ Result: There should be a maximum gap of 0.062 inches (1.57 mm) between the roller wheel and the column.

**NOTICE** If mast inspection results in a measurement that is not within specification, refer to Repair procedure 2-1, *How to Disassemble the Mast Assembly*.

TABLE C PROCEDURES

- 4 Visually inspect the bottom of each column for clearance between the roller wheel and the adjacent column surface.

- ⊙ Result: There should be a maximum gap of 0.062 inches (1.57 mm) between the roller wheel and the column.

**NOTICE** If mast inspection results in a measurement that is not within specification, refer to Repair procedure 2-1, *How to Disassemble the Mast Assembly*.

### C-3 Replace the Winch Friction Disks

Maintaining the winch is essential to good machine performance and safe operation. An unsafe working condition exists if the winch has excessive wear and/or does not operate smoothly, free of hesitation and binding.

- 1 Replace the winch friction disks. See Repair procedure 3-1, *How to Disassemble the Winch*.

### C-4 Inspect the Safety Brake System (If Equipped)

Detection of damage or a defect to the safety brake system is essential for safe machine operation. An unsafe working condition exists if the system is damaged or defective and does not allow the mast to sequence properly, free of hesitation and binding.

**AWARNING** This procedure requires specific repair skills and a suitable workshop. Attempting this procedure without these skills may result in death or serious injury or significant component damage. Dealer service is strongly recommended.

**CAUTION** Be sure to wear protective gloves to perform this procedure.

- 1 Install a load handling attachment into the carriage. Do not place any weight on the load handling attachment.
  - 2 Raise the carriage until it is half way up the front column.
  - 3 Physically hold the bottom side of the carriage and lift it approximately 12 inches (30.5 cm), then drop it.
- ⊙ Result: The carriage should stop within 5 to 8 inches (12.7 to 20.3 cm) and the safety brake should lock.

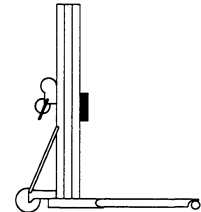

**CAUTION** Crushing hazard. Do not stand directly under columns.

- 4 Raise the carriage 12 inches (30.5 cm) to unlock the safety brake.
  - 5 Continue raising the carriage until the front column is half way up the adjacent column.
  - 6 Physically hold the bottom side of the front column, and lift it approximately 12 inches (30.5 cm), then drop it.
- ⊙ Result: The column should stop within 5 to 8 inches (12.7 to 20.3 cm) and the safety brake should lock.

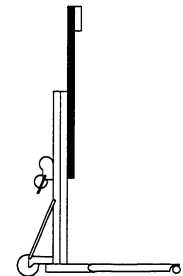

**CAUTION** Crushing hazard. Do not stand directly under columns.

- 7 Raise the front column 12 inches (30.5 cm) to unlock the safety brake.
- 8 Continue raising the carriage until the front column is fully raised and the next column is half way up the adjacent column.

TABLE C PROCEDURES

- 9 Physically hold the bottom side of the next column, and lift it approximately 12 inches (30.5 cm), then drop it.

- ⊙ Result: The column should stop within 5 to 8 inches (12.7 to 20.3 cm) and the safety brake should lock.

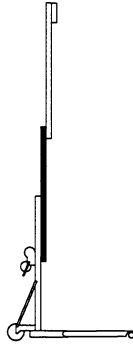

**CAUTION** Crushing hazard. Do not stand directly under columns.

- 10 Repeat steps 7 through 9 to test all remaining columns.

**NOTICE** When unlocking the safety brake, it may be necessary to hold down the column behind the brake to be unlocked.

**NOTICE** The number one column (column attached to base) does not have a safety brake and will not need to be tested.

## C-5 Inspect the Painted Surfaces

Inspecting the painted surfaces of your machine is essential to safe operation. An unsafe working condition exists if there is damage to painted surfaces that is not corrected.

- 1 Visually inspect all painted surfaces for the following conditions:
  - blistering
  - rust
  - peeling
  - fading
  - corrosion

**NOTICE** Repair or replace any component if it is damaged.

# Troubleshooting Flow Charts



## Observe and Obey:

- ☑ Troubleshooting and repair procedures shall be completed by a person trained and qualified on the repair of this machine.
- ☑ Immediately tag and remove from service a damaged or malfunctioning machine.
- ☑ Repair any machine damage or malfunction before operating the machine.
- ☑ Be sure the capacities of sawhorses or other supports are sufficient to withstand machine weight. See Specification section for specific weight.
- ☑ Be sure overhead cranes or other lifting devices are of ample capacity to handle machine weight. See Specification section for specific weight.

## Before Troubleshooting:

- ☑ Read, understand and obey the safety rules and operating instructions printed in the *Genie Superlift Contractor Operator's Manual*.
- ☑ Be sure that all necessary tools and test equipment are available and ready for use.
- ☑ Read each appropriate flow chart thoroughly. Attempting shortcuts may produce hazardous conditions.
- ☑ Be aware of the following hazards and follow generally accepted safe workshop practices.

**⚠ DANGER** Crushing hazard. When testing or replacing primary component, always support the structure and secure it from movement.

**ℹ NOTICE** Perform all troubleshooting on a firm level surface.

**ℹ NOTICE** Two persons will be required to safely perform some troubleshooting procedures.

## About This Section

When a malfunction is discovered, the flow charts in this section will help a service professional pinpoint the cause of the problem. To use this section, basic hand tools are required.

### General Repair Process

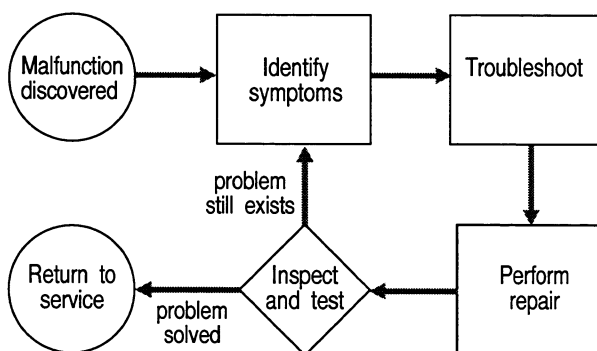

# Chart 1

## Mast Will Not Sequence Properly

Be sure safety brake (if equipped) is not locked by fully raising and lowering all columns.

Mis-sequencing of the mast columns may occur when the machine is at or near maximum capacity. If mis-sequencing occurs, the columns may shift to their correct position during continued operation or when the load is removed. This shift will not result in a drop of the forks. The carriage should always raise first, and lower last.

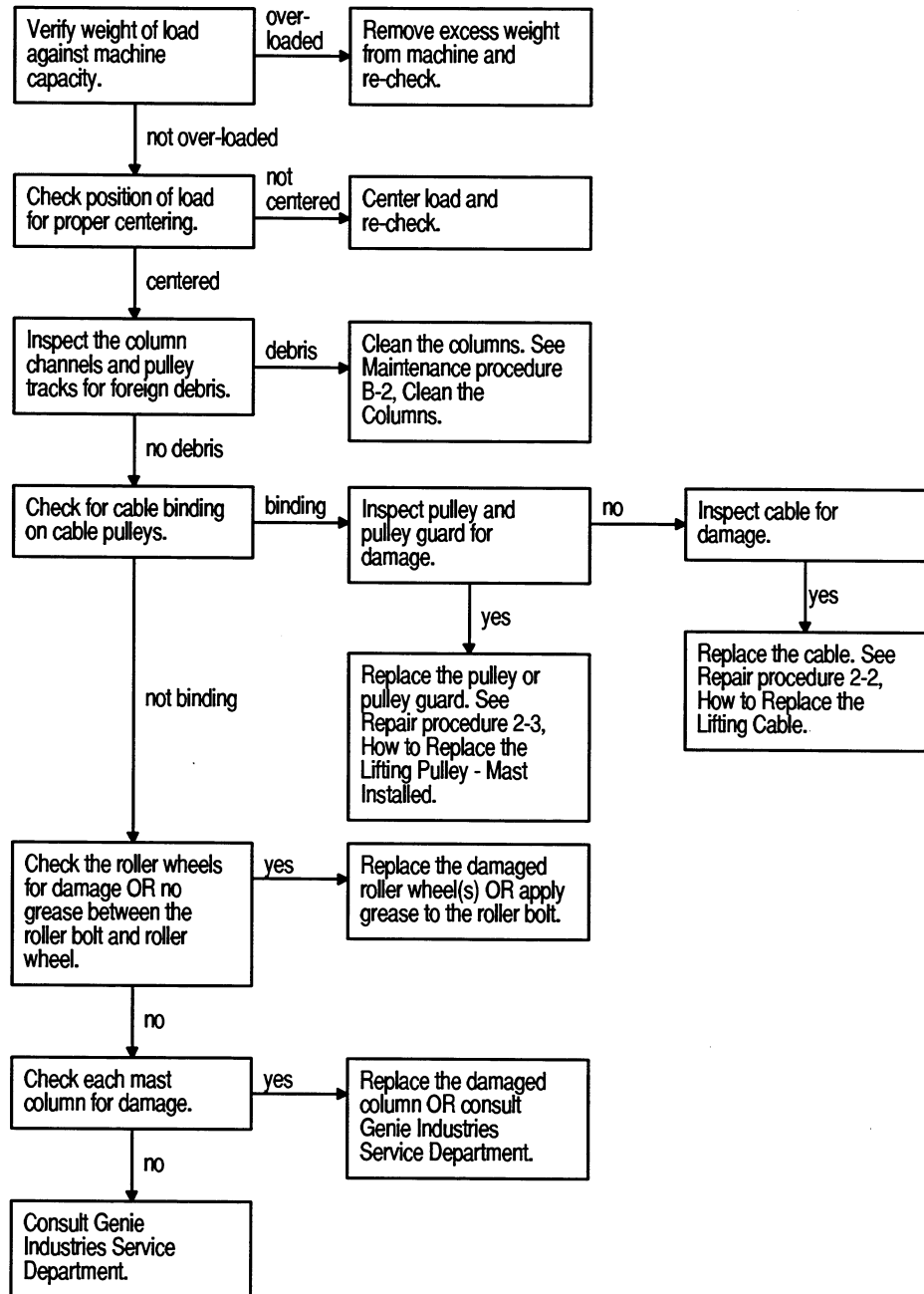

## Chart 2

### Carriage Will Not Raise, But Winch Will Operate

Be sure the carriage hold down bar is not contacting the carriage.

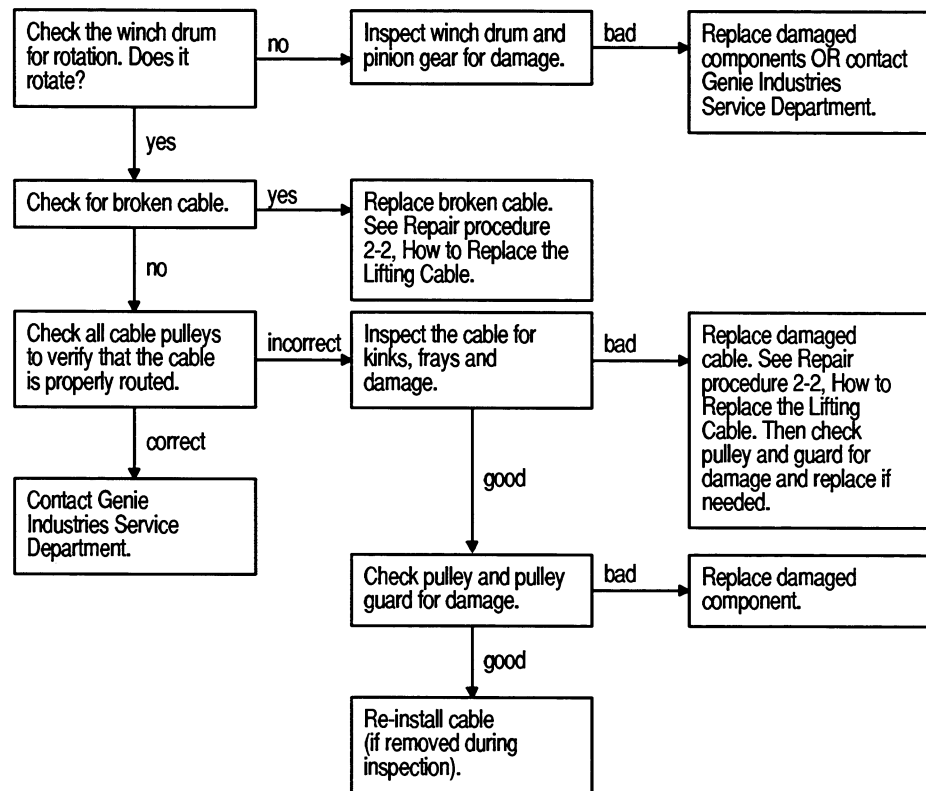



# Chart 3

## Winch Will Not Operate

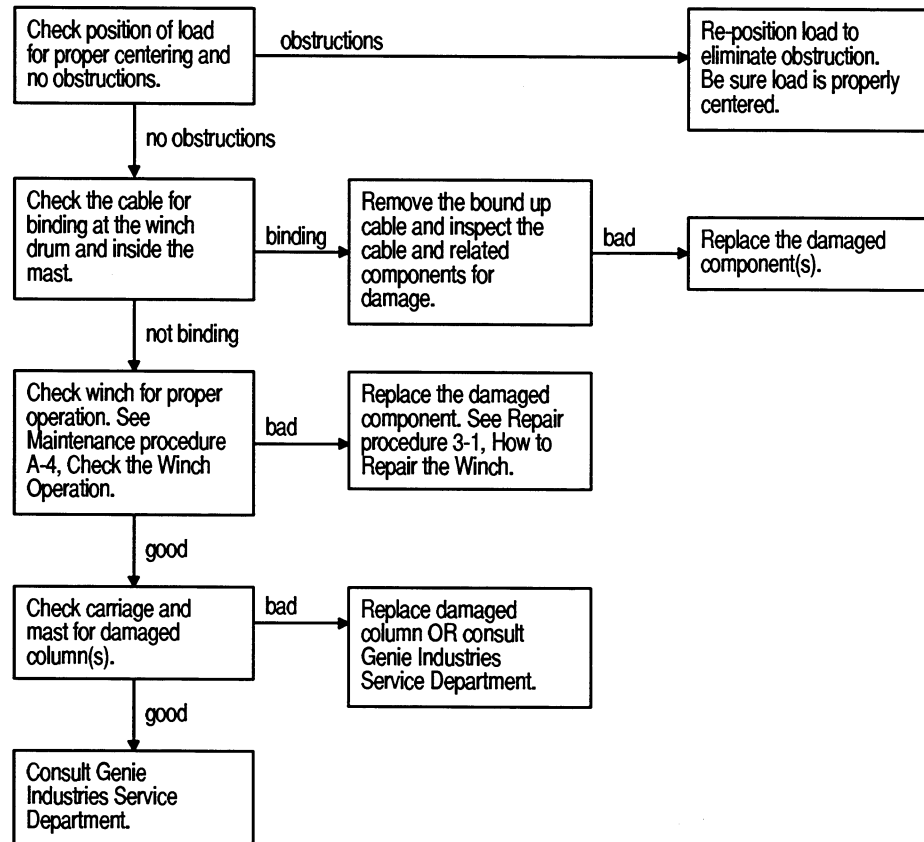

# Repair Procedures



## Observe and Obey:

- ☑ Repair procedures shall be completed by a person trained and qualified on the repair of this machine.
- ☑ Immediately tag and remove from service a damaged or malfunctioning machine.
- ☑ Repair any machine damage or malfunction before operating the machine.

## Before Repairs Start:

- ☑ Read, understand and obey the safety rules and operating instructions in the *Genie Superlift Contractor Operator's Manual*.
- ☑ Be sure that all necessary tools and parts are available and ready for use.
- ☑ Be sure the capacities of sawhorses or other supports are sufficient to withstand machine weight. See Specification section for specific weight.
- ☑ Be sure overhead cranes or other lifting devices are of ample capacity to handle machine weight. See Specification section for specific weight.
- ☑ Read each procedure completely and adhere to the instructions. Attempting shortcuts may produce hazardous conditions.
- ☑ Unless otherwise specified, perform each procedure with the machine in the following configuration:
  - machine positioned on a flat level surface
  - carriage fully lowered
  - casters locked

## About This Section

Most of the procedures in this section should only be performed by a trained service professional in a suitably equipped workshop. Select the appropriate repair procedure after troubleshooting the problem.

Perform disassembly procedures to the point where repairs can be completed. Then to re-assemble, perform the disassembly steps in reverse order.

## General Repair Process

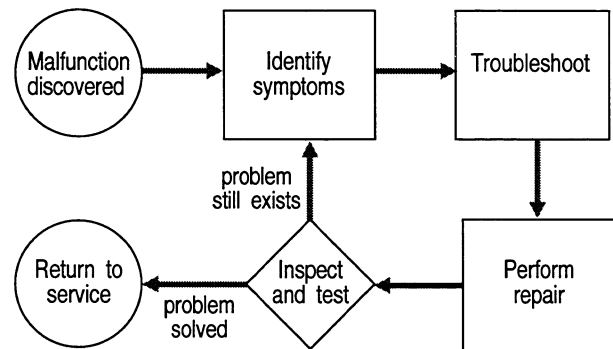

## Symbols Legend

**⚠ DANGER** Indicates the presence of a hazard that **will** cause death or serious injury.

**⚠ WARNING** Indicates the presence of a hazard that **may** cause death or serious injury.

**⚠ CAUTION** Indicates the presence of a hazard that **will** or **may** cause serious injury or damage to the machine.

**NOTICE** Indicates special operation or maintenance information.

⦿ Indicates that a specific result is expected after performing a series of steps.

# Base Assembly

## 1-1 How to Remove the Base

- 1 Fully lower the carriage.
- 2 Remove the load handling attachment from the machine.

### Machines with stabilizers:

- 3 Remove the mounting fasteners from the stabilizer mounting bracket on the back of the mast.
- 4 Remove the mounting fastener from each of the stabilizers at the base. Remove the stabilizers from the machine.

### All Models:

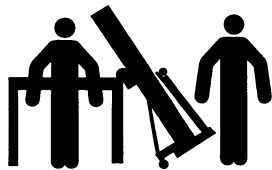
- 5 Using proper lifting techniques, tilt the machine back and rest the loading wheels against a sawhorse or other suitable support.
 
- 6 Remove the mounting fastener and retaining pin from each leg. Then remove the legs from the machine.
- 7 Using proper lifting techniques, tilt the machine to the upright position.
- 8 Attach an overhead crane to the lifting bracket on the number 1 mast.
- 9 Place a sawhorse on the carriage side of the mast.

- 10 Lift the machine slightly and then while lowering it, guide the machine over onto the sawhorse.

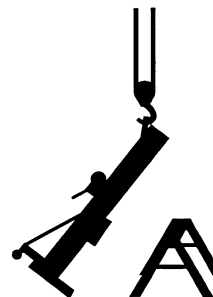

**CAUTION** Crushing hazard. The machine will fall unless it is properly supported with the overhead crane.

- 11 Secure the top of the mast to the sawhorse.
- 12 Attach an overhead crane to the base and lift the machine enough to slide a second sawhorse under the mast, next to the base.

**CAUTION** Crushing hazard. The machine will fall unless it is properly supported with the overhead crane.

- 13 Remove the mounting fasteners from the mast brace to the base. Repeat for other side.
- 14 Remove the base mounting fasteners. Then remove the base from the machine.

# Mast Assembly

## 2-1

### How to Disassemble the Mast Assembly

- 1 Remove the cable retaining fasteners from the winch drum. Then remove all of the cable from the drum.
- 2 Tip the machine backwards and rest the top of the number one mast on an appropriate support. The mast assembly should be level with the carriage up.



**CAUTION** Bodily injury hazard. Use proper lifting techniques.

- 3 Remove the mounting fastener from the cable anchor on the last column (carriage side).
- 4 Remove the cable from the mast by pulling on the cable anchor end of the cable.

**CAUTION** Bodily injury hazard. Cables can fray. Always wear adequate hand protection when handling cable.

- 5 Slide the carriage forward about 1 foot (30 cm) to expose the column stop mounting fastener attached to the bottom end of the top column, below the carriage. Remove the fastener and the column down stop.
- 6 **Models with safety brake:** Use a hex key wrench through the access holes in the carriage to release the safety brake. Slide the carriage away from the base 1 inch (2.5 cm) while reaching through both slots. Position the hex key above the safety brake rollers and pull back on the wrench.
- 7 **Models with safety brake:** Remove the carriage by sliding it out the bottom of the mast towards the base while holding the safety brake rollers in position with the hex key wrench.

- 7 **Models without safety brake:** Remove the carriage by sliding it out the bottom of the mast towards the base.
- 8 Repeat steps 5 through 7 for each remaining column.

### How to Release the Safety Brake When Servicing the Mast

The safety brake system will lock when the machine is tilted horizontally. When the brake is locked, the columns can extend but not retract. If the safety brake system locks while you are servicing the mast, use one of the following methods described below to release the brake.

- A The first method allows you to release each column successively starting at the carriage and removing columns one by one. This is described above in How to Disassemble the Mast Assembly, steps 5-8.
- B The second method allows you to release any column in the assembly regardless of position but requires a custom made tool. The tool is a piece of  $1/8$  to  $5/16$  inch diameter stiff wire bent in an L shape with one end 1 inch long and the other end 16 inches long. The installation of a handle on the 16" end will make it easier to use. This tool is available from Genie Industries (Genie part number 33875).



Using the special tool, reach from the bottom of the column and into the safety brake access slot in the inner side wall of the column. Slide the carriage away from the base about 1 inch (2.5 cm) while reaching through the far upper end of the slot. Position the short end of the tool above the safety brake rollers and pull back on the tool. Slide the released column out the bottom of the mast assembly.

## MAST ASSEMBLY

**How to Assemble the Mast**

- 1 Inspect all mast parts for wear and damage, replace as necessary.
  - 2 Clean all of the columns and rollers.
  - 3 Clean all of the safety brake assemblies (if equipped).
  - 4 Position the number one column so that it is open side up and level. If it is not attached to the base, secure the column to your sawhorses or work table before proceeding.
  - 5 Install all column assembly components (if removed during disassembly). Apply a small amount of grease between the roller bolt head and the inside of the roller wheel.
  - 6 Slide the number two column into the number one from the bottom. Stop inserting the column when the top of the column up stop or the safety brake assembly is even with the bottom of the number one column.
  - 7 Repeat with all remaining columns. All columns should be sticking out of the next lower column. Do not install the carriage.
- NOTICE** Cable is installed after all columns are together as an assembly.
- 8 Attach the swaged end of the cable to the cable anchor on the top of the front column.
  - 9 With the other end of the cable in hand, feed it through the box section (web) of the carriage into the pulley and push it through the pulley until it comes out the back side of the carriage.
- CAUTION** Bodily injury hazard. Cables can fray. Always wear adequate hand protection when handling cable.
- NOTICE** Refer to figure 7-F, in the parts section to identify the cable routing.
- 10 Insert the carriage into the bottom end of the top column. Hold the carriage from moving and pull the cable up to the top of the column, leaving enough slack so that you can feed the cable through the next pulley.
  - 11 Push the cable through the exposed portion of the pulley at the top of the column until the cable reaches the pulley at the bottom of the column.
  - 12 Using needle nose pliers, insert the cable end into the cable pulley. Push the cable through the pulley until the end comes out.
  - 13 Push the cable between the two mast sections until it comes out the top of the column.
  - 14 Repeat steps 11 through 13, until all the columns are cabled.
  - 15 Slide all the columns forward, until you can install the column stops. Do not slide the columns forward, further than necessary.
  - 16 Install all the components removed during disassembly.
  - 17 Attach the cable to the winch and be sure cable is routed correctly.
  - 18 Raise all the columns to full height to verify proper operation and release the safety brakes (if equipped).

**2-2****How to Replace the Lifting Cable**

- NOTICE** All Genie replacement cables come with one preswaged end that terminates to the last column and one taped end that terminates to the winch.

**CAUTION** Bodily injury hazard. Cables can fray. Always wear adequate hand protection when handling cable.

- 1 Fully lower the carriage.
- 2 Wrap a piece of strapping tape around the cable just below the swaged end of the cable.

## MAST ASSEMBLY

- 3 Remove the cable from the winch drum.
- 4 Cut the cable where you placed the tape.

**NOTICE** Cable must be cut using a cutting tool which will not leave frays on the end of the cable.

- 5 Using the cable re-threading tool that came with your cable, insert even amounts of cable into each end of the tool.
- 6 Pull the old cable out from the winch and pull in new cable at the same time.

**NOTICE** If cable gets caught as you are pulling it through the columns and pulleys, take care not to pull too hard as you can break the connection between the two cables. Try pulling the cable back and forth until the cable pulls free.

## 2-3

### How to Replace a Lifting Pulley - Mast Installed

- 1 Fully lower the carriage.
- 2 Unwind approximately 1 to 2 feet (0.30 to 0.60 meters) of cable from the winch drum.
- 3 Tip the machine backwards and rest the top of the number one mast on an appropriate support. The mast assembly should be level with the carriage up.

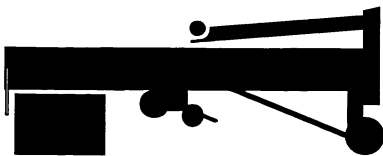

- 4 If replacing an upper pulley, slide the column that is above the pulley to be replaced forward. If replacing a lower pulley, slide the column with the pulley to be replaced forward. Push the column forward about 6 inches (15.2 cm) to expose the lower column stop.

- 5 Remove the column stop.
- 6 Slide the column backwards until the pulley to be replaced is exposed.
- 7 Remove the two mounting fasteners from the pulley mounting block. Then remove the pulley assembly.
- 8 Remove the bolt that attaches the pulley to the mounting block.

**NOTICE** Note where the shims are located before disassembling.

- 9 Remove the old pulley. Install the cable onto the new pulley, then install the pulley onto the column.

**CAUTION** When installing the cable onto the pulley, make sure the cable does not get twisted or sequencing and other mast related problems will occur.

**NOTICE** Make sure the cable guard is located over the retaining pin on the pulley mounting block. Make sure the pulley spins freely after reassembling the pulley assembly.

- 10 Attach the pulley assembly to the column.
- 11 Assemble the columns in reverse order of disassembly.
- 12 Repeat the procedure for other pulleys to be replaced.

# Winch

## 3-1

### How to Disassemble the Winch

**CAUTION** Bodily injury hazard. Cables can fray. Always wear adequate hand protection when handling cable.

- 1 Fully lower the carriage.
- 2 Remove the cable retaining fastener from the winch drum. Then remove the cable from the drum.
- 3 Remove the handles from the pinion shaft.
- 4 Remove the drum bolt and the drum bolt spacer. Then remove the drum and drum gear cover and the housing spacer from the winch.
- 5 Remove the two lock nuts from the pinion shaft by holding the opposite end of the shaft by the flattened portion of the threads.

**CAUTION** Be careful not to damage the threads while holding the pinion shaft.

- 6 Remove the retaining ring from the pinion shaft.
- 7 Slide the pinion shaft to the left and remove the pinion spacer, pinion plate, ratchet gear and friction disks. Remove the pinion gear by turning it counterclockwise, then slide it off the right side of the shaft.
- 8 Remove the pinion shaft from the winch housing.
- 9 Remove both pinion bushings. Use a soft metal drift equal to the outside diameter of the bushing and tap with rubber mallet.

**CAUTION** Place a block in between the walls of the winch housing to prevent the housing from bending while removing the bushings.

- 10 Remove the winch housing from the machine.

### How to Assemble the Winch

**CAUTION** Bodily injury hazard. Cables can fray. Always wear adequate hand protection when handling cable.

**NOTICE** Refer to Section Seven, Figure 7-1, for exploded view of the winch.

- 1 Place one side of the winch housing over a vise. Open the vise until it is wider than the outside diameter of the bushing.
- 2 Insert a soft metal drift through the opposite bushing hole. Tap the drift with a rubber mallet to push the bushing into place. Repeat steps 1 and 2 to insert the other bushing.

**NOTICE** Use a piece of flatbar between the drift and the bushing to prevent any damage to the bushing.

- 5 Add two drops of 30W oil to both pivot points on each ratchet pawl.

**CAUTION** Do not allow grease or oil onto the brake friction disks or the ratchet gear.

- 6 Install the winch housing onto the mast. Be sure the winch drum is towards the top.
- 7 Insert the longer threaded end of the pinion shaft through the left bushing approximately half way.
- 8 Apply a small amount of automotive grease to the large threaded section of the pinion shaft, under the gear nut. Install the pinion gear onto the pinion shaft with the gears towards the left wall of the winch housing. Screw onto the large threads hand tight.
- 9 Install a friction disk, ratchet gear, friction disk, pinion plate and pinion spacer in respective order onto the pinion shaft.

## WINCH

- NOTICE** The teeth on the ratchet gear must curve away from the right side wall of the winch housing.
- CAUTION** Do not allow grease or oil onto the friction disks or the ratchet gear.
- 10 Push the pinion shaft to the right, through the right pinion bushing and install the pinion shaft retaining ring.
- NOTICE** Use your fingers to push the ratchet pawls outwards while pushing pinion shaft through the right bushing. Be sure the ratchet pawls are in firm contact with the ratchet gear and all parts move freely.
- 11 Install the two jam nuts to the right side of the pinion shaft one at a time and tighten.
- 12 Install a handle to both sides of the pinion shaft in opposite directions and secure with a lock nut on each end of the pinion shaft.
- 13 Lubricate the outside of the frame spacer that goes through the cable drum with automotive grease and then insert it into the drum.
- 14 Install the cable drum so that the drum gears mesh with the ratchet gears.
- 15 Install the drum bolt keeper onto the drum bolt and then insert the drum bolt through the winch housing and drum with the head of the drum bolt on the drum gear side of the winch.
- 16 Place the drum gear cover into position with the drum bolt slot under the drum bolt keeper.
- 17 Install the drum bolt jam nut hand tight.
- 18 Install the housing spacer with the head of the housing spacer bolt on the right side of the winch and through the slotted portion of the drum gear cover. Place the nut on the end of the bolt and tighten.

- 19 Tighten and torque the drum bolt nut to 20 to 25 ft. lbs.

**CAUTION** Overtightening the drum bolt jam nut may cause damage to the frame spacer and prevent the drum from spinning freely.

- 20 Lubricate with automotive grease the teeth of the drum gear and the pinion nut that meshes with the drum gear.

**CAUTION** Do not allow grease or oil onto the friction disks or the ratchet gear.

- 21 Rotate the drum so that the two square cable keeper holes are at the top. Install the cable keeper clip to the outside of the drum with the two carriage bolts coming through from the inside. Install the lock washers and nut. Do not tighten down the nuts at this point.

- 22 Route the end of the cable around the winch drum and out through the remaining hole on the left side wall of the drum.

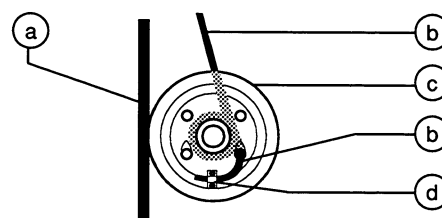

- a number one column  
b cable  
c winch drum  
d cable keeper clip

- 23 Insert the end of the cable under the cable keeper clip approximately  $\frac{1}{2}$  inch and tighten the cable keeper clip.

- 24 While holding the cable tight on the drum, rotate the drum with a handle and spool the cable onto the drum neatly. Be sure there are 4 wraps of cable on the drum

**CAUTION** Component damage hazard. Be sure the cable winds onto the winch drum evenly.



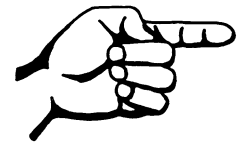

This page intentionally left blank.

How to Read Your Serial Number

**Genie.**  
 A TEREX BRAND  
 Terex South Dakota, Inc  
 18340 NE 76th Street  
 Redmond, WA 98052 USA

Model Name: SLC-6

Serial Number: SLC03-12345

Manufacture Date: 01/02/03

Electrical Schematic: N/A

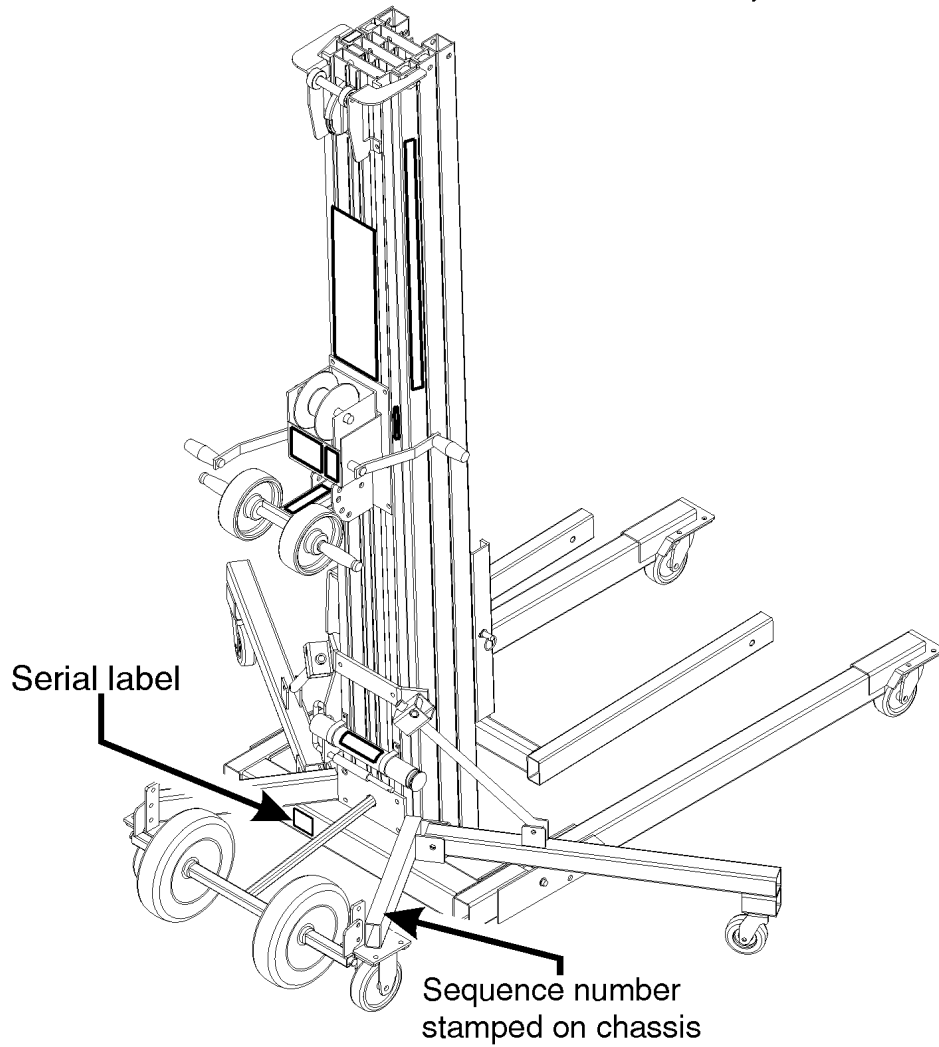
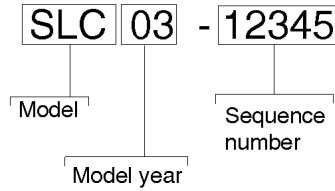
October 2014

## Parts Stocking List

**Required Parts**

The following parts are required to perform maintenance procedures as outlined in the *Genie Superlift Contractor Service Manual*.

Description	Part No.
White Lithium Grease .....	91670
Disc Brake (One-Speed Winch).....	7571
Disc Brake (Two-Speed Winch).....	37061

**Recommended Parts**

Description	Part No.
Genie Blue Paint, 1 Gallon (3.78 liters) .....	32150
Genie Blue Paint, 12 Ounce Aerosol (355 ml).....	1484
Genie Gray Paint, 1 Gallon (3.78 liters) .....	32151
Genie Gray Paint, 12 Ounce Aerosol (355 ml) .....	1268
Ratchet Pawl Kit (One-Speed Winch) .....	40458
Ratchet Pawl Kit (Two-Speed Winch) .....	40117
Cable Keeper Kit (One-Speed Winch) .....	6190
Replacement Coupler .....	12402
Cable Assembly (SLC-6 models).....	35005
Cable Assembly (SLC-12 models).....	6099
Cable Assembly (SLC-18 models).....	7250
Cable Assembly (SLC-24 models).....	7251
Pin Assembly with Lanyard.....	100309
Roller Bolt, 1/2-13 x 1.84 inches.....	32475
Nylatron Roller, 1.75 x 0.72 inch.....	32473
Safety Brake Assembly .....	35101
Loctite Thread Lock .....	65764
Genie Superlift Cabling Procedure Video .....	52701

**Manuals**

Genie Industries offers the following support documents for these models:

Title	Part No.
Genie Superlift Contractor Operator's Manual, Second Edition .....	33547
Genie Superlift Contractor Service Manual, Third Edition .....	115409
EMI Safety Manual .....	27581
Manual of Responsibilities ANSI A92.5 .....	31587

## How To Order Parts

### How To Order Parts

Please be prepared with the following information when ordering replacement parts for your Terex or Genie product:

- Machine model number
- Machine serial number
- Part number
- Part description and quantity
- Purchase order number
- "Ship to" address
- Desired method of shipment
- Name and telephone number of the authorized distributor in your area

Use the Service Parts Fax Order Form on the next page and fax your order to our Parts Department.

If you don't know the name of your authorized distributor, or if your area is not currently serviced by an authorized distributor, please call Terex or Genie Industries.

### Machine Information

\_\_\_\_\_

Model

\_\_\_\_\_

Serial Number

\_\_\_\_\_

Date of Purchase

\_\_\_\_\_

Authorized Genie Distributor

\_\_\_\_\_

Phone Number

#### North America

Telephone (425) 556-6551  
 Toll Free (877) 367-5606 in U.S.A. and Canada  
 Fax (425) 556-8659  
 Toll Free Fax (888) 274-6192

#### Europe

Parts Telephone (31) (165) 519 313  
 Parts Fax (31) (165) 511 148

#### Australia

Parts Telephone (61) (7) 3456 4444  
 Parts Fax (61) (7) 3456 4466

#### South America

Parts Telephone (55) (11) 4082 5600  
 Parts Fax (55) (11) 4082 5630



**Service Parts Fax Order Form**

Fax to: (425) 556-8659 or Toll Free: 888-274-6192  
International: +1-425-556-8659

**Please fill out completely**

Date \_\_\_\_\_ Account Number \_\_\_\_\_  
 Your Name \_\_\_\_\_ Your Fax Number \_\_\_\_\_  
 \_\_\_\_\_ Your Phone Number \_\_\_\_\_  
 Bill To \_\_\_\_\_ Ship To \_\_\_\_\_  
 \_\_\_\_\_  
 \_\_\_\_\_  
 \_\_\_\_\_  
 Purchase Order Number \_\_\_\_\_ Ship Via \_\_\_\_\_

Model(s) \_\_\_\_\_ Serial No.(s) \_\_\_\_\_

Optional Equipment \_\_\_\_\_

Part Number	Description	Quantity	Price

All back-ordered parts will be shipped when available via the same ship method as the original order unless Noted below:

- Ship complete order only - No back orders
- Ship all available parts and contact customer on disposition of back-ordered parts
- Other (please specify)

101.1 Decals with Words (to SLC04-28240)

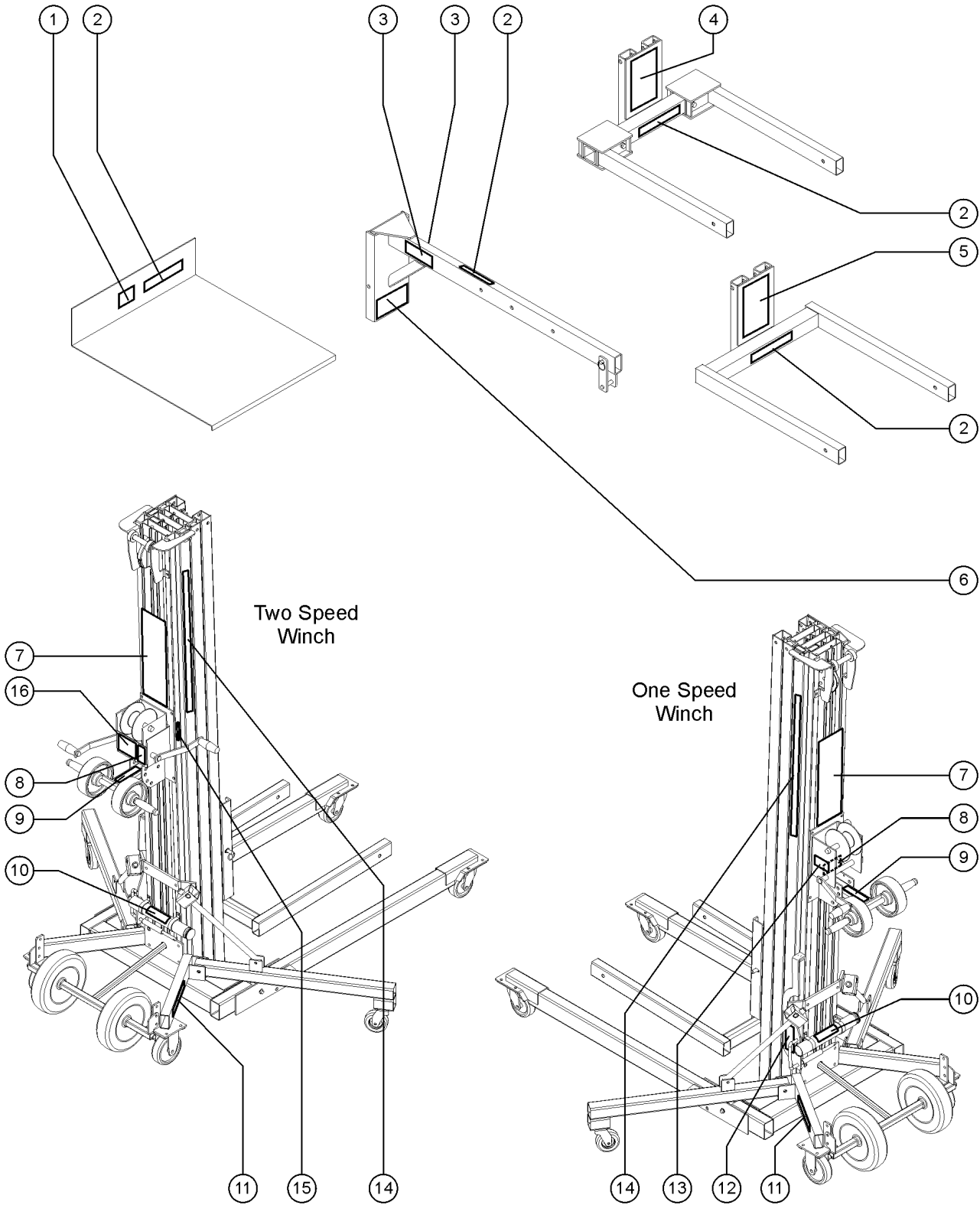

101.1 Decals with Words (to SLC04-28240)

Item	Part No.	Description	Qty.
--	48373	DECAL KIT, SAFETY/INST, SLC to SN SLC04-28240; includes items 2, 5, 7-10 and 12-13	
1	32775	DECAL,WARNING,FALL HAZARD.....	1
2	33468	DECAL,WARNING,NO RIDERS.....	1
3	32716	DECAL,NOTICE BOOM SETUP.....	2
4	32714	DECAL,WARNING ADJ FORK SETUP.....	1
5	32687	DECAL,WARNING STD.FORK SAFETY.....	1
6	32717	DECAL,WARNING BOOM SAFETY.....	1
7	40513	DECAL,WARNING/SAFETY-SLC..... (replaced 33545 from SN 9596-5288)	1
8	32938	DECAL,LABEL,WINCH ONLY.....	1
9	32939	DECAL,CRUSHING HAZ/BRAKE LOCK.....	1
10	31072	DECAL,LABEL,OPER.MAN.STORAGE.	1
11	52992	DECAL,COSMETIC,SLC-6.....	2
11A	52993	DECAL,COSMETIC,SLC-12	
11B	52994	DECAL,COSMETIC,SLC-18	
11C	52995	DECAL,COSMETIC,SLC-24	
12	52675	DECAL,CAUTION,DAMAGD MACHINE.....	1
13	32885	DECAL,SILENT WINCH.....	1
14	52984	DECAL,GENIE SUPERLIFT CONTRACT.....	2
15	33982	SERIAL NUMBER PLATE, SL CONTR.....	1
16	32770	DECAL,2 SPD.WINCH**.....	1

103.1 Decals with symbols

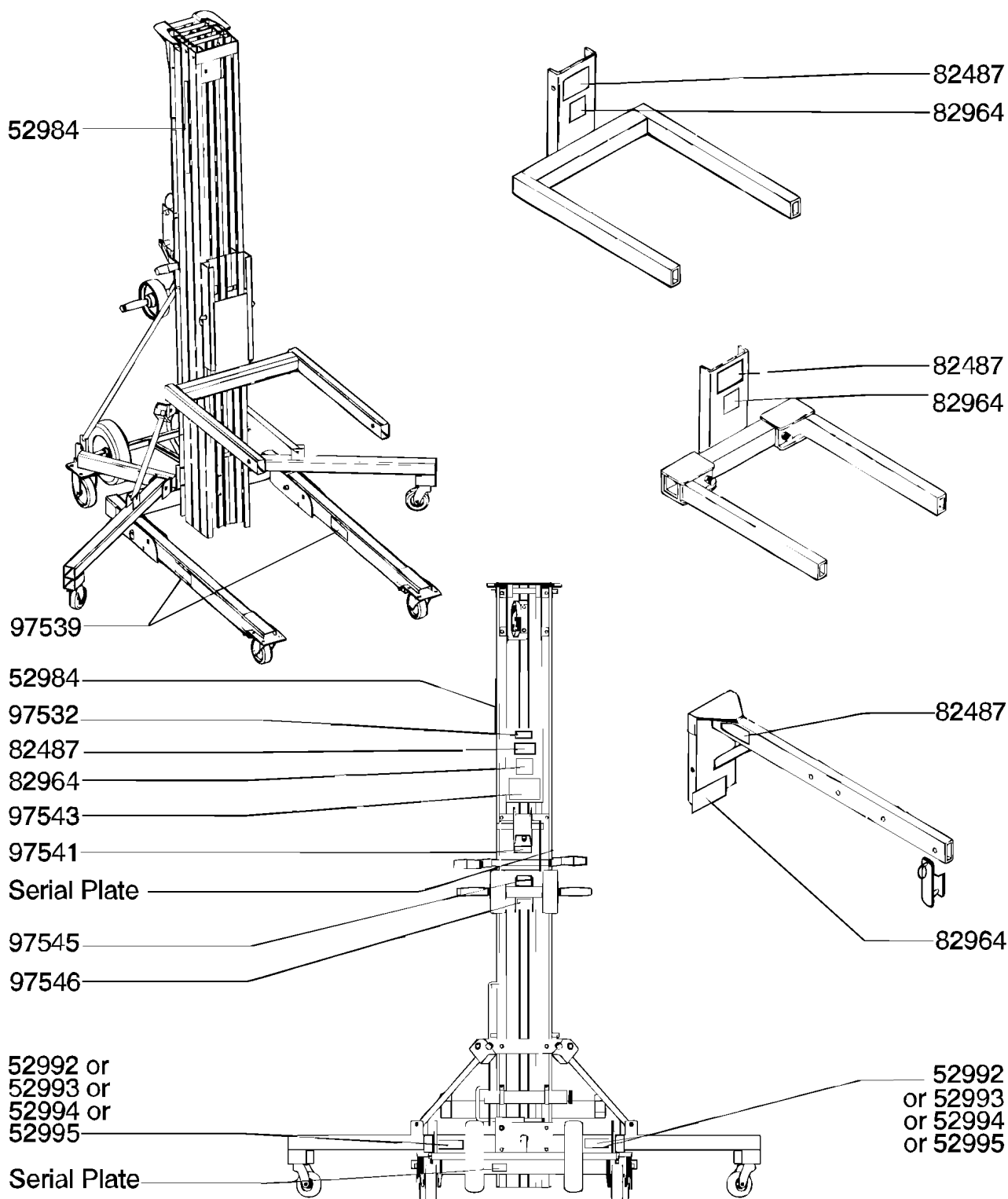



103.1 Decals with symbols

Item	Part No.	Description	Qty.
1	52984	DECAL,GENIE SUPERLIFT CONTRACT.....	2
2	52992	DECAL,COSMETIC,SLC-6.....	2
2A	52993	DECAL,COSMETIC,SLC-12	
2B	52994	DECAL,COSMETIC,SLC-18	
2C	52995	DECAL,COSMETIC,SLC-24	
3	82487	DECAL,SYMBOL-READ THE MANUAL.....	1
4	82964	DECAL,WARNING,NO RIDERS SYMB.....	1
5	97532	DECAL,CAUTION,MOVING PARTS SYM.....	1
6	97539	DECAL,DANGER,ELEC.HAZ.....	2
7	97541	DECAL,LABEL,WINCH ONLY SYMB.....	1
8	97543	DECAL,WARNING,LOAD CHART SLC.....	1
9	97545	DECAL,WARNING,BRAKE LOCK SYMB.....	1
10	97546	DECAL,2 SPD.WINCH SYMB.....	1

200 Base Components

October 2014

201.1 Base Components, View 1

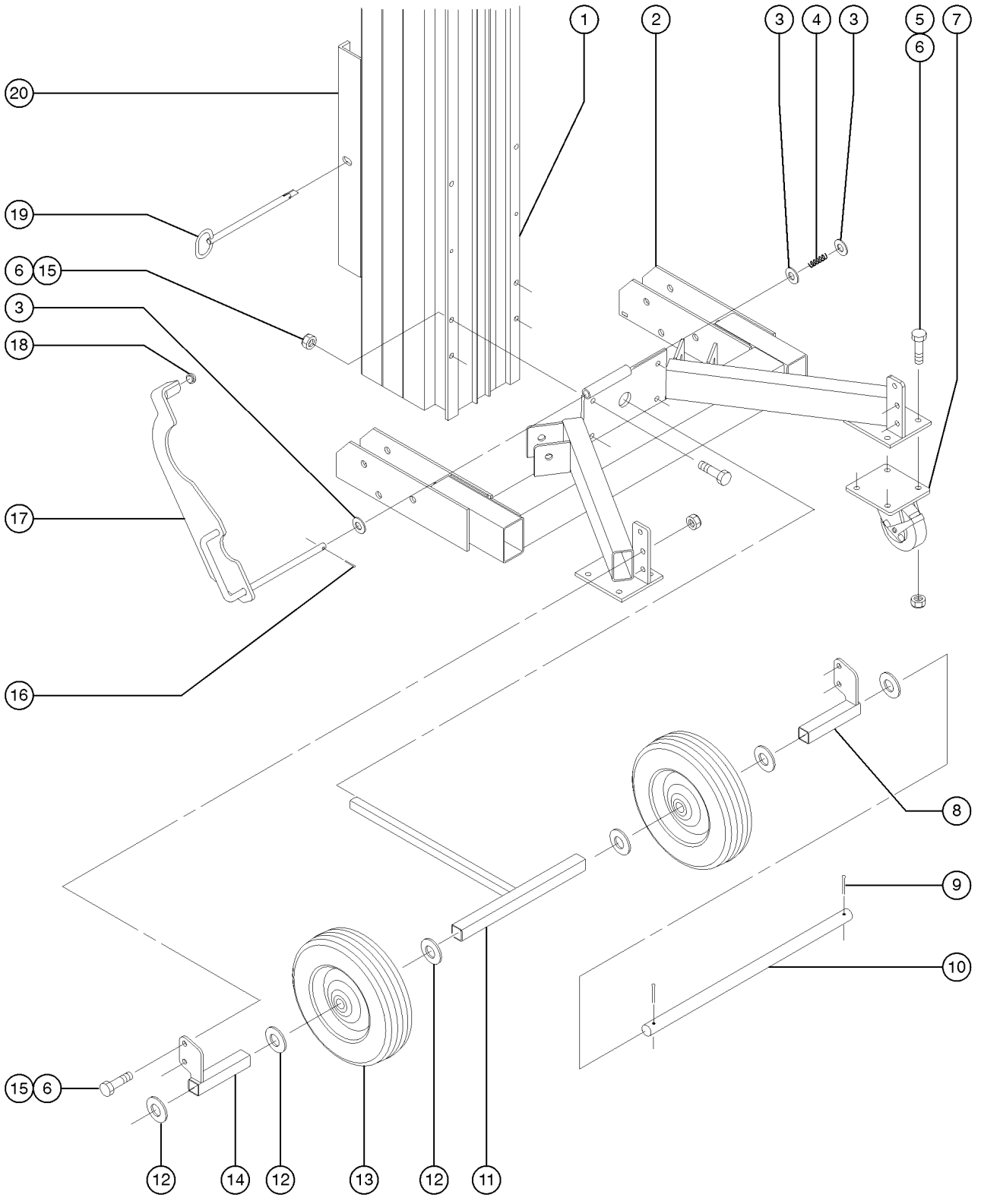

Item	Part No.	Description	Qty.
1		Ref. Columns (refer to 304.1)	
2	80141-S	BASE ASSY W/DECALS,SLC-6.....1	
2A	80142-S	BASE ASSY W/DECALS, SLC-12....1	
2B	80143-S	BASE ASSY W/DECALS, SLC-18....1	
2C	80144-S	BASE ASSY W/DECALS, SLC-24....1	
3	21443	SHIM,.75 X.45 X.064.....3	
4	33658	SPRING,HOLDOWN SL2E.....1	
5	6175	SCREW,HHC,3/8-16 X 1	
6	4828	NUT,NYLOCK,3/8-16	
7	57735	CASTER,PL,SW,SB, 5 X 1.5***.....2	
8	33830-S	WHEEL SPACER MOUNT WELD,RH,SL.....1	
9	6094	PIN,COTTER,.125 X 1.....2	
10	57237	AXLE ROD, TRANSPORT WHEEL,SL.....1	
11	33831-S	WHEEL SPACER WELDMENT,SL"GRAY".....1	
12	6564	WASHER,SHIM,.765X1.312 X.093**.....6	
13	35064	WHEEL,SOLID RUBBER,10X.75X2.75.....2 (to SN SLC07-39655)	
14	33829-S	WHEEL SPACER MNT WELD LH,SL.....1	
15	6019	SCREW,HHC,3/8-16 X 1.25 GRD 5	
16	12016	PIN,COTTER,.125 X .75.....1	
17	58750	HOLD DOWN KIT W/DECAL SL SHORT.....1 SLC-6 (includes item numbers 16 and 18)	
17A	58095	HOLD DOWN KIT W/DECAL SL LONG.....1 SLC-12, SLC-18, SLC-24 (includes items numbers 16 and 18)	
18	11890	GLIDE BUTTON,SIDE,GLL,.100 TK.....1	
19	48301	PIN,TOGGLE,.50 X 8.13***.....1	
20		Ref. Carriage (refer to 304.1)	

200 Base Components

October 2014

202.1 Base Components, View 2

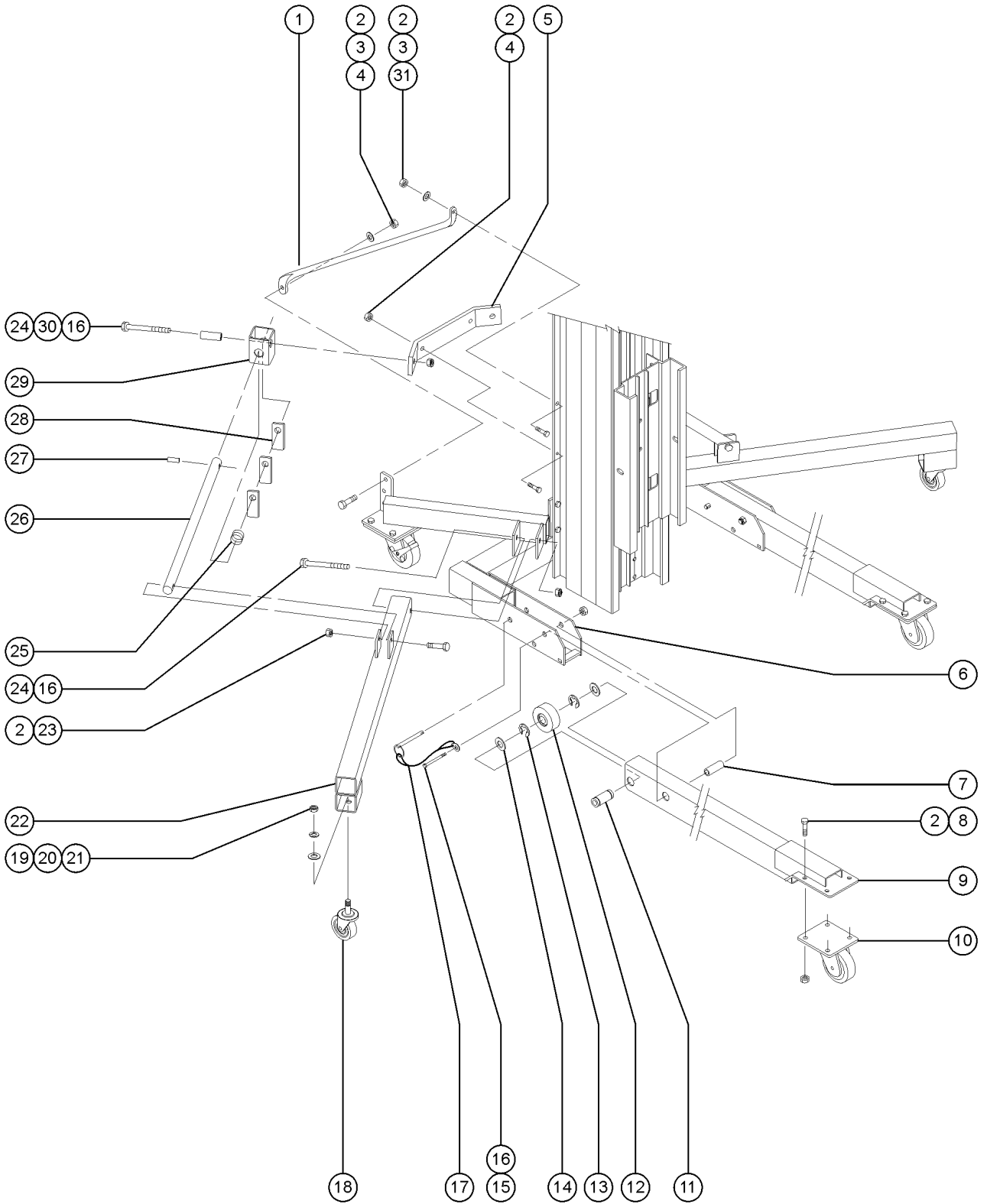

A TEREX BRAND

October 2014

200 Base Components

202.1 Base Components, View 2

Item	Part No.	Description	Qty.	Item	Part No.	Description	Qty.
--	35159-S	SLC, STABILIZER ASSY(SET)/SERV		31	8516	SCREW,HHC,3/8-16 X 1.50,GR5.....4	
1	32883	STRUT, LH, SL2.....1	1				
1A	32884	STRUT, RH, SL2.....1 <i>shown</i>	1				
2	4828	NUT,NYLOCK,3/8-16					
3	6097	WASHER,FLAT,USS,3/8",Y					
4	8516	SCREW,HHC,3/8-16 X 1.50,GR5					
5	35212	BRACKET, STAB.MOUNT,"GRAY".....1	1				
6		Ref. Base Assembly with Decals.....1 <i>(refer to 201.1)</i>	1				
7	32509	PIVOT TUBE SL2 LEG.....2	2				
8	6175	SCREW,HHC,3/8-16 X 1					
9	35015	WELDMENT, LEG, SLC-6 GRAY.....2	2				
9A	35016	WELDMENT, LEG, SLC-12 GRAY					
9B	35017	WELDMENT,LEG,SLC-18 GRAY***					
9C	35018	WELDMENT, LEG, SLC-24 GRAY					
10	57734	CASTER,SL,SW, 4 X 1.5.....2	2				
11	32524	AXLE TUBE, SL2 LEG.....2	2				
12	57782	WHEEL,POLYOLEFIN,2.5X1.25,7/8.2					
13	32499	E CLIP,.875 IN.SL LEG.....4	4				
14	33373	WASHER,SHIM,1.50 X .890 X .09...4	4				
15	10598	SCREW,HHC,1/2-13 X 3					
16	6086	NUT,LP NYLOCK,1/2-13					
17	100309	ASSY,PIN & LANYARD***.....2	2				
18	57746	CASTER,POST,SW,3.5X1.25,1/2-13.2					
19	6034	NUT,HEX,JAM,1/2-13					
20	6033	WASHER,LOCK,0.5"					
21	6095	WASHER,FLAT,USS,1/2",Y					
22	35019	WELDMENT, STABILIZER, SLC GRAY.....2	2				
23	5224	SCREW,HHC,3/8-16 X 2					
24	6732	SCREW,HHC,1/2-13 X 3.25					
25	32519	SPRING,STABILIZER LATCH SL2.....2	2				
26	58094	STABILIZER STRUT,ASSY.....2 <i>(includes item 27)</i>	2				
27	11337	PIN,ROLL,.25 X 1.25.....2	2				
28	32577	LATCH PLATE,STABILIZER SL2.....6	6				
29	35213	CLAMP TUBE,STABILIZER-"GRAY".....2	2				
30	32576	PIVOT TUBE,STABILIZER.....2	2				

300 Mast and Winch Components

October 2014

301.1 Mast Components, View 1

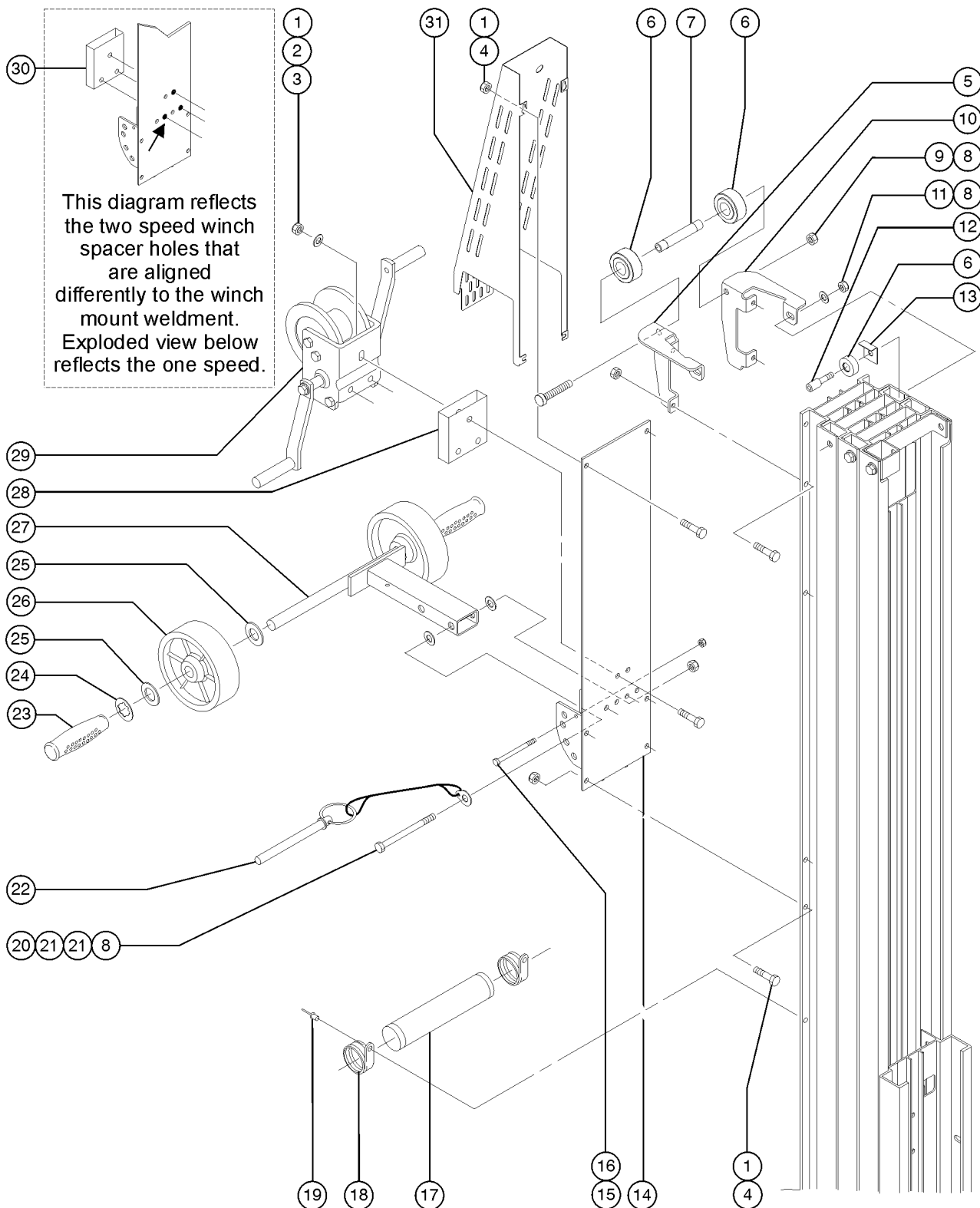

301.1 Mast Components, View 1

Item	Part No.	Description	Qty.	Item	Part No.	Description	Qty.
--	35814	MAST STIFFENER KIT <i>includes 5-10</i>		27	100301	WELDMNT, LOADING WHEEL AXLE.....	1
--	90337	BOE LUBE..... <i>aluminum dry lubricant</i>	1	27A	33618	WELDMNT,LOADING WHEEL,GRAY,SLC	
1	4828	NUT,NYLOCK,3/8-16		27B	33540	LOADING WHEEL ASSY ST/SL <i>(assembly with word decals) (includes items 23-26)</i>	
2	6097	WASHER,FLAT,USS,3/8",Y..... <i>(one speed winch)</i>	1	27C	35819	LOADING WHEEL WELD.W/DECAL SL2 <i>(assembly with symbol decals) (includes items 23-26)</i>	
2A	6097	WASHER,FLAT,USS,3/8",Y..... <i>(two speed winch)</i>	3	28	35834	WINCH SPACER,1 SPEED SLC, GRAY.....	1
3	6326	SCREW,HHC,3/8-16 X 3 SLC-6, SLC-12		29		Ref. Winch Assembly <i>(refer to 305.1 or 306.1)</i>	
3A	6175	SCREW,HHC,3/8-16 X 1 SLC-18, SLC-24		30	49991	WINCH SPACER, 2 SPEED SLC,GRAY.....	1
4	6019	SCREW,HHC,3/8-16 X 1.25 GRD 5		31	124790	KIT,CBL GRD,W/WRD DCALS,SLC..... <i>(Australia models) (assembly with word decals) (from SN SLC08-46919)</i>	1
5	109579	MAST STIFFENER,RIGHT,GRAY***.....	1				
6	32473	WHEEL,ROLLER,NYLATRON,1.75.2					
7	33843	SPACER,MAST STIFFENER.....	1				
8	6198	NUT,NYLOCK,1/2-13					
9	13005	SCREW,HHC,1/2-13 X 6,GRD.8.....	1				
10	109580	MAST STIFFENER,LEFT,GRAY***.....	1				
11	6095	WASHER,FLAT,USS,1/2",Y					
12	32475	BOLT-ROLLER,1/2-13X1.84 ZINC....	2				
13	32474	GUARD,ROLLER, SL2,.....	2				
14	33539	WINCH PLATE W/DECAL ST.....	1				
15	12343	SCREW,HHC,1/4-20 X 3					
16	6091	NUT,NYLOCK,1/4-20.....	1				
17	6600	INSTRUCT.TUBE W/CAPS-1.75 X 12.....	1				
--	31822	CAP,INSTRUCTION TUBE (RED)					
18	6653	CLAMP,1.88,#30 X 1/4,RUB CUSH.....	2				
19	7265	RIVET,STEEL,P, .25 X .375.....	2				
20	6732	SCREW,HHC,1/2-13 X 3.25					
21	11978	WASHER,FLAT,NYLON.515X.88X.093					
22	100309	ASSY,PIN & LANYARD***.....	1				
23	6587	HANDLE GRIP, RUBBER .75 X 4.5.....	2				
24	33385	WASHER,PUSH ON .75 SHAFT....	2				
25	6564	WASHER,SHIM,.765X1.312 X.093**					
26	57788	WHEEL,POLY,6X2, 3/4**.....	2				

300 Mast and Winch Components

October 2014

302.1 Mast Components, View 2

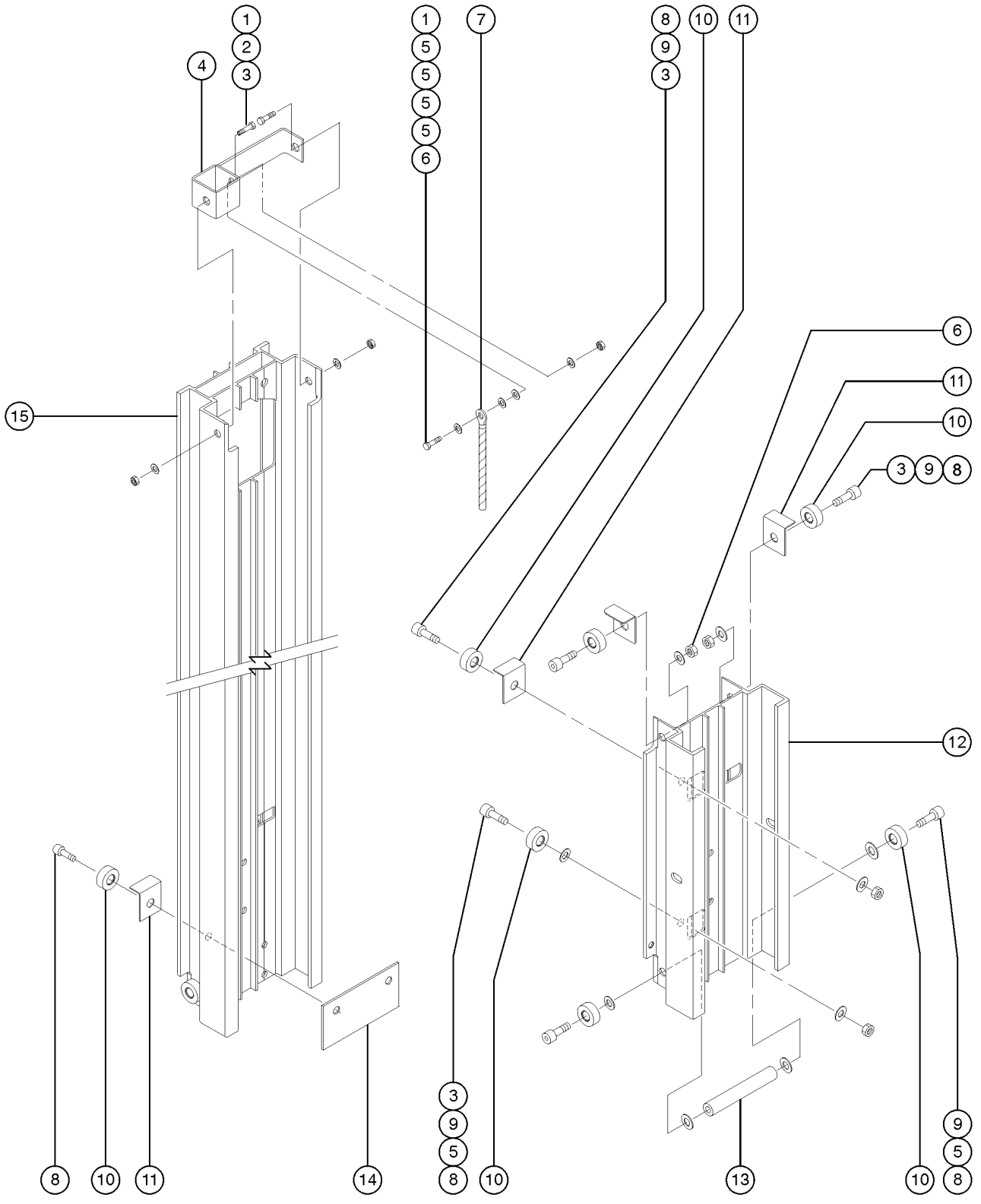

A TEREX BRAND



Item	Part No.	Description	Qty.
1	10597	SCREW,HHC,1/2-13 X 1.25 GR5	
2	6095	WASHER,FLAT,USS,1/2",Y	
3	6198	NUT,NYLOCK,1/2-13	
4	80987	KIT, CABLE ANCHOR BRK, SLC/ST* .....1	
5	6052	WASHER,SHIM,.5 X .875 X .063	
6	6086	NUT,LP NYLOCK,1/2-13	
7		Ref. Cable Assembly (refer to 304.1)	
8	32475	BOLT-ROLLER,1/2-13X1.84 ZINC....8	
9	13066	WASHER,FLAT,.5 HARDENED.....6	
10	32473	WHEEL,ROLLER,NYLATRON,1.75.8	
11	32474	GUARD,ROLLER, SL2,.....5	
12		Ref. Carriage (refer to 304.1)	
13	33811	COUPLER BAR ASSEMBLY,SLA&C,ST2.....1	
14	57016	PLATE,DOUBLER,SL MAST.....1	
15		Ref. Number 1 Column (refer to 304.1)	

# 300 Mast and Winch Components

October 2014

## 303.1 Mast Components, View 3

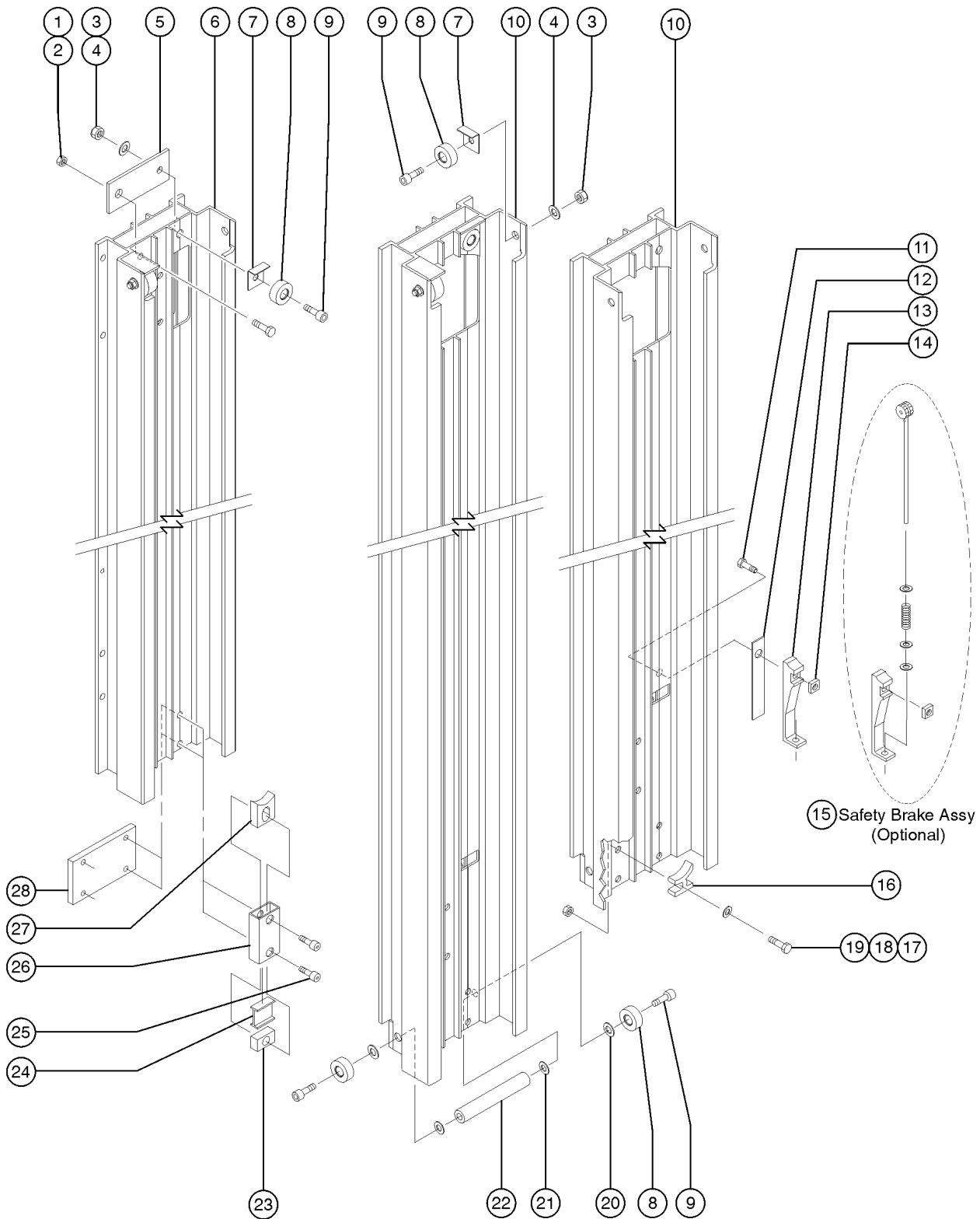

303.1 Mast Components, View 3

Item	Part No.	Description	Qty.	Item	Part No.	Description	Qty.
1	7713	NUT,LP NYLOCK,3/8-16		9A	32475	BOLT-ROLLER,1/2-13X1.84 ZINC.....	10
2	8255	SCREW,HHC,3/8-16 X .75				SLC-12	
3	6198	NUT,NYLOCK,1/2-13.....	3	9B	32475	BOLT-ROLLER,1/2-13X1.84 ZINC.....	17
		SLC-6				SLC-18	
3A	6198	NUT,NYLOCK,1/2-13.....	6	9C	32475	BOLT-ROLLER,1/2-13X1.84 ZINC.....	24
		SLC-12				SLC-24	
3B	6198	NUT,NYLOCK,1/2-13.....	9	10		Ref. Number 2 Column <i>(refer to 304.1)</i>	
		SLC-18		11	35463	SCREW,FHS,3/8-16 X 1.5.....	1
3C	6198	NUT,NYLOCK,1/2-13.....	12			SLC-6	
		SLC-24		11A	35463	SCREW,FHS,3/8-16 X 1.5.....	2
4	6095	WASHER,FLAT,USS,1/2",Y.....	3			SLC-12	
		SLC-6		11B	35463	SCREW,FHS,3/8-16 X 1.5.....	3
4A	6095	WASHER,FLAT,USS,1/2",Y.....	6			SLC-18	
		SLC-12		11C	35463	SCREW,FHS,3/8-16 X 1.5.....	4
4B	6095	WASHER,FLAT,USS,1/2",Y.....	9			SLC-24	
		SLC-18		12	35442	SHIM,SAFETY BRAKE, SLC.....	1
4C	6095	WASHER,FLAT,USS,1/2",Y.....	12			SLC-6	
		SLC-24		12A	35442	SHIM,SAFETY BRAKE, SLC.....	2
5	57016	PLATE,DOUBLER,SL MAST.....	1			SLC-12	
6		Ref. Number 1 Column <i>(refer to 304.1)</i>		12B	35442	SHIM,SAFETY BRAKE, SLC.....	3
7	32474	GUARD,ROLLER, SL2,.....	3			SLC-18	
		SLC-6		12C	35442	SHIM,SAFETY BRAKE, SLC.....	4
7A	32474	GUARD,ROLLER, SL2,.....	8			SLC-24	
		SLC-12		13	35443	UP STOP.....	2
7B	32474	GUARD,ROLLER, SL2,.....	13			SLC-12 (models without safety brake) <i>(not shown)</i>	
		SLC-18		13A	35443	UP STOP.....	2
7C	32474	GUARD,ROLLER, SL2,.....	18			SLC-18 (models without safety brake) <i>(not shown)</i>	
		SLC-24		13B	35443	UP STOP.....	3
8	32473	WHEEL,ROLLER,NYLATRON,1.75.3				SLC-24 (models without safety brake) <i>(not shown)</i>	
		SLC-6		14	35408	NUT,SQUARE 3/8-16 NC, PLATED.....	1
--	40153	ROLLER KIT(SLA,SLC)-1EA. <i>includes one roller with fasteners</i>				SLC-6	
--	40154	ROLLER KIT(SLA,SLC)-6EA. <i>includes six rollers with all fasteners</i>		14A	35408	NUT,SQUARE 3/8-16 NC, PLATED.....	2
--	40155	ROLLER KIT(SLA,SLC)-20EA <i>includes twenty rollers with all fasteners</i>				SLC-12	
8A	32473	WHEEL,ROLLER,NYLATRON,1.75.10		14B	35408	NUT,SQUARE 3/8-16 NC, PLATED.....	3
		SLC-12				SLC-18	
8B	32473	WHEEL,ROLLER,NYLATRON,1.75.17		14C	35408	NUT,SQUARE 3/8-16 NC, PLATED.....	4
		SLC-18				SLC-24	
8C	32473	WHEEL,ROLLER,NYLATRON,1.75.24					
		SLC-24					
9	32475	BOLT-ROLLER,1/2-13X1.84 ZINC....	3				
		SLC-6					



## 300 Mast and Winch Components

October 2014

303.1 Mast Components, View 3  
(continued)

Item	Part No.	Description	Qty.	Item	Part No.	Description	Qty.
15	35101	SAFETY BRAKE ASSY(SQ.NUT)SL2**.....1 SLC-6	1	25	57023	BOLT,SHOULDER,3/8-16 1.417 LNG.....2 SLC-12	2
15A	35101	SAFETY BRAKE ASSY(SQ.NUT)SL2**.....2 SLC-12	2	25A	57023	BOLT,SHOULDER,3/8-16 1.417 LNG.....8 SLC-18	8
15B	35101	SAFETY BRAKE ASSY(SQ.NUT)SL2**.....3 SLC-18	3	25B	57023	BOLT,SHOULDER,3/8-16 1.417 LNG.....12 SLC-24	12
15C	35101	SAFETY BRAKE ASSY(SQ.NUT)SL2**.....4 SLC-24	4	26	57021	TUBE,DOWNSTOP.....2 SLC-12	2
16	32522	DOWN STOP.....1	1	26A	57021	TUBE,DOWNSTOP.....4 SLC-18	4
17	6175	SCREW,HHC,3/8-16 X 1		26B	57021	TUBE,DOWNSTOP.....6 SLC-24	6
18	5397	WASHER,FLAT,USS,5/16",Y		27	57018	BLOCK,PLUNGER,DOWNSTOP....2 SLC-12	2
19	4828	NUT,NYLOCK,3/8-16		27A	57018	BLOCK,PLUNGER,DOWNSTOP....4 SLC-18	4
20	6052	WASHER,SHIM,.5 X .875 X .063....2 SLC-12	2	27B	57018	BLOCK,PLUNGER,DOWNSTOP....6 SLC-24	6
20A	6052	WASHER,SHIM,.5 X .875 X .063....4 SLC-18	4	28	57024	PLATE,DOUBLER,DOWNSTOP....1 SLC-12	1
20B	6052	WASHER,SHIM,.5 X .875 X .063....6 SLC-24	6	28A	57024	PLATE,DOUBLER,DOWNSTOP....2 SLC-18	2
21	13066	WASHER,FLAT,.5 HARDENED		28B	57024	PLATE,DOUBLER,DOWNSTOP....3 SLC-24	3
22	33811	COUPLER BAR ASSEMBLY,SLA&C,ST2.....1 SLC-6	1				
22A	33811	COUPLER BAR ASSEMBLY,SLA&C,ST2.....2 SLC-12	2				
22B	33811	COUPLER BAR ASSEMBLY,SLA&C,ST2.....3 SLC-18	3				
22C	33811	COUPLER BAR ASSEMBLY,SLA&C,ST2.....4 SLC-24	4				
23	57019	BLOCK,END,DOWNSTOP.....2 SLC-12	2				
23A	57019	BLOCK,END,DOWNSTOP.....4 SLC-18	4				
23B	57019	BLOCK,END,DOWNSTOP.....6 SLC-24	6				
24	57022	BUMPER,RUBBER,DOWNSTOP....2 SLC-12	2				
24A	57022	BUMPER,RUBBER,DOWNSTOP....4 SLC-18	4				
24B	57022	BUMPER,RUBBER,DOWNSTOP....6 SLC-24	6				

***This Page Intentionally Left Blank***

304.1 Columns, Pulleys and Cables

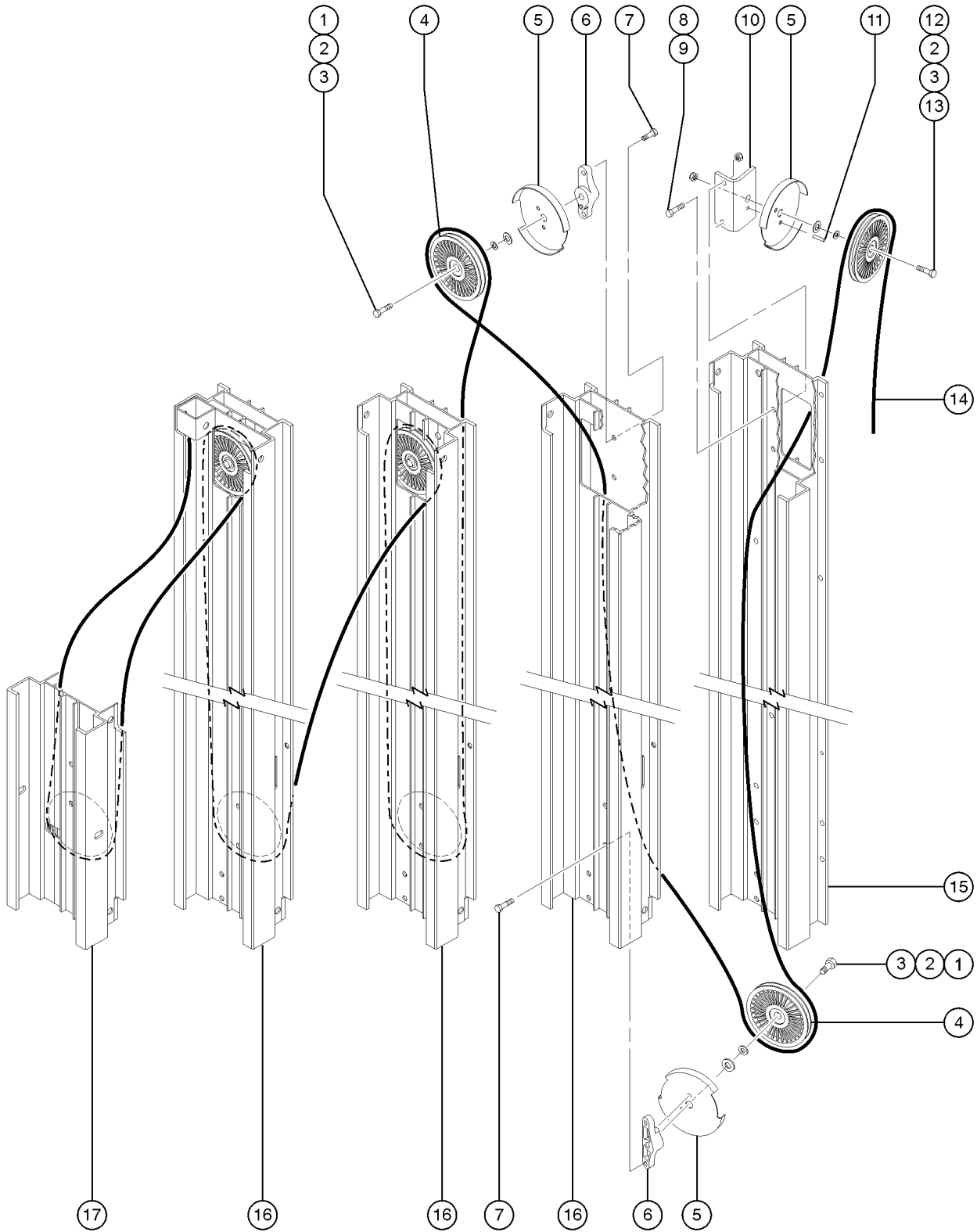

October 2014

## 300 Mast and Winch Components

## 304.1 Columns, Pulleys and Cables

Item	Part No.	Description	Qty.	Item	Part No.	Description	Qty.
1	10597	SCREW,HHC,1/2-13 X 1.25 GR5.....1 SLC-6	1	6	32470	PULLEY MOUNT , SL-2.....1 SLC-6	1
1A	10597	SCREW,HHC,1/2-13 X 1.25 GR5.....3 SLC-12	3	6A	32470	PULLEY MOUNT , SL-2.....3 SLC-12	3
1B	10597	SCREW,HHC,1/2-13 X 1.25 GR5.....5 SLC-18	5	6B	32470	PULLEY MOUNT , SL-2.....5 SLC-18	5
1C	10597	SCREW,HHC,1/2-13 X 1.25 GR5.....7 SLC-24	7	6C	32470	PULLEY MOUNT , SL-2.....7 SLC-24	7
2	37038	WASHER,FLAT,.5X .125,HARDENED* .....2 SLC-6	2	7	8255	SCREW,HHC,3/8-16 X .75.....2 SLC-6	2
2A	37038	WASHER,FLAT,.5X .125,HARDENED* .....4 SLC-12	4	7A	8255	SCREW,HHC,3/8-16 X .75.....6 SLC-12	6
2B	37038	WASHER,FLAT,.5X .125,HARDENED* .....6 SLC-18	6	7B	8255	SCREW,HHC,3/8-16 X .75.....8 SLC-18	8
2C	37038	WASHER,FLAT,.5X .125,HARDENED* .....8 SLC-24	8	7C	8255	SCREW,HHC,3/8-16 X .75.....10 SLC-24	10
3	6052	WASHER,SHIM,.5 X .875 X .063.....2 SLC-6	2	8	6019	SCREW,HHC,3/8-16 X 1.25 GRD 5	
3A	6052	WASHER,SHIM,.5 X .875 X .063.....4 SLC-12	4	9	4828	NUT,NYLOCK,3/8-16	
3B	6052	WASHER,SHIM,.5 X .875 X .063.....6 SLC-18	6	10	33700	PULLEY MOUNT,#1 COLUMN,GRY,SLC.....1	1
3C	6052	WASHER,SHIM,.5 X .875 X .063.....8 SLC-24	8	11	32483	PIN,ROLL,.25 X .50.....1	1
4	49999	PULLEY W/BEARING 4.65X.5 '98** .....2 SLC-6	2	12	22788	SCREW,HHC,1/2-13 X 1.75	
4A	49999	PULLEY W/BEARING 4.65X.5 '98** .....4 SLC-12	4	13	6198	NUT,NYLOCK,1/2-13	
4B	49999	PULLEY W/BEARING 4.65X.5 '98** .....6 SLC-18	6	14	35005	CABLE ASSEMBLY, SLC-6.....1 SLC-6; Does not Include Cable Replacement Coupler	1
4C	49999	PULLEY W/BEARING 4.65X.5 '98** .....8 SLC-24	8	--	12402	CABLE REPLACEMENT COUPLER Sold Separately	
5	32476	GUARD,CABLE*** .....2 SLC-6 (to SN SLC02-21794)	2	--	52701	VIDEO,NTSC,SLA,CABLING PROCDR Sold Separately	
5A	32476	GUARD,CABLE*** .....4 SLC-12 (to SN SLC02-21794)	4	14A	6099	CABLE ASSEMBLY SL 408" SLC-12; Does not Include Cable Replacement Coupler	
5B	32476	GUARD,CABLE*** .....6 SLC-18 (to SN SLC02-21794)	6	14B	7250	CABLE ASSY SL/ST 588" 3/16"*** SLC-18; Does not Include Cable Replacement Coupler	
5C	32476	GUARD,CABLE*** .....8 SLC-24 (to SN SLC02-21794)	8	14C	7251	CABLE ASSY SL/ST 756" 3/16"*** SLC-24; Does not Include Cable Replacement Coupler	
				15	57028-S	COLUMN#1,MACHINED,SLC SERV.....1	1
				16	57029-S	COLUMN#2,,MACHINED,SLC SERV.....1 quantity depends on height of unit.	1
				17	57031	CARRIAGE,SL CONTRACTOR***...1	1

300 Mast and Winch Components

October 2014

305.1 Winch Components - Single Speed

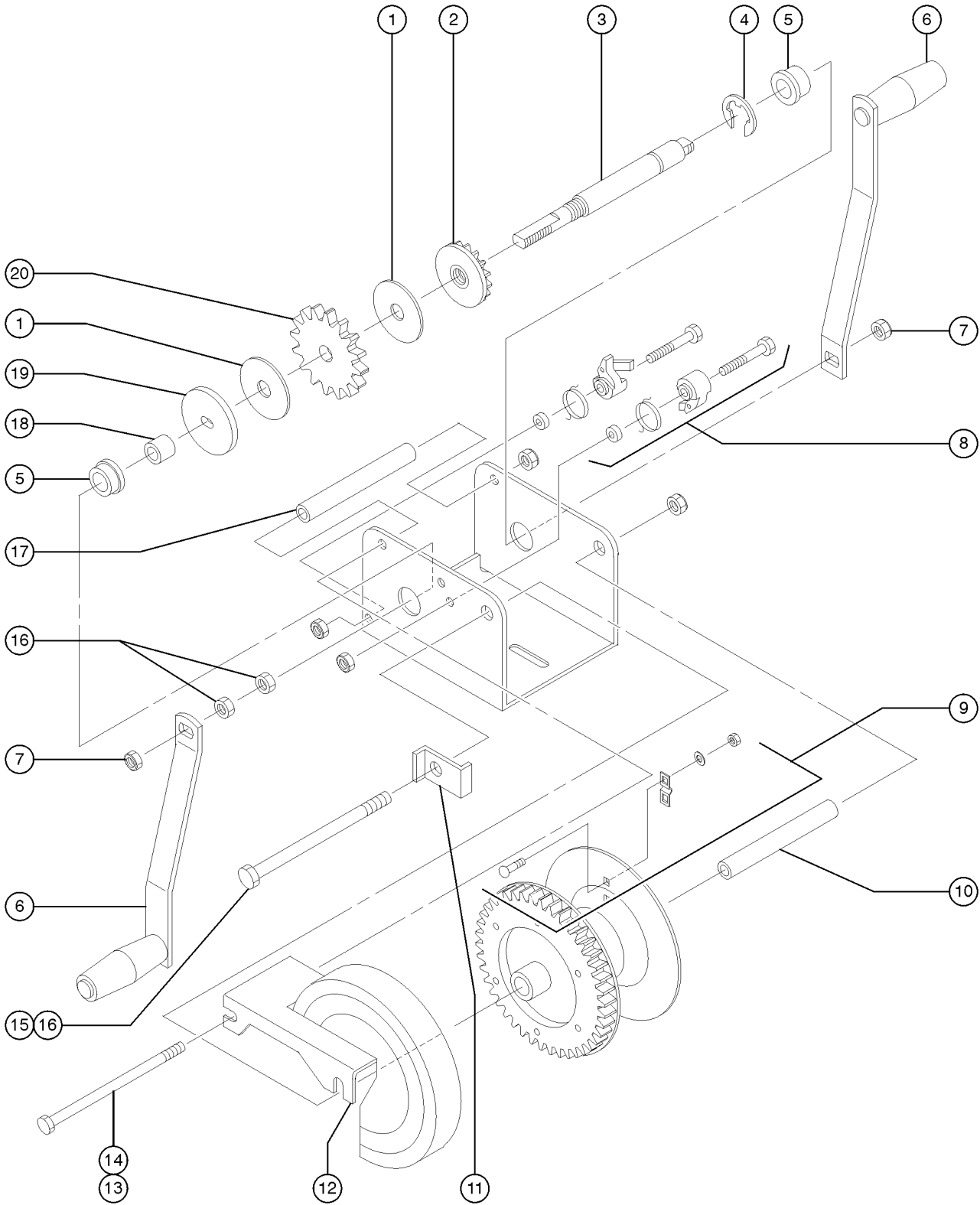

A TEREX BRAND



October 2014

## 300 Mast and Winch Components

## 305.1 Winch Components - Single Speed

Item	Part No.	Description	Qty.
--	32945	WINCH,W/DECAL 1SPEED SL/ST (refer to 101.1, 102.1 or 103.1) (handle not included)	
1	7571	BRAKE DISK,.5 BORE,K-1550.....2	
2	7590	PINION GEAR AND DISC K-1550...1	
3	32891	SHAFT,PINION (32891).....1	
4	6200	RETAINING RING.....1	
5	6199	BUSHING, SMALL PINION, FULTON.....2	
6	33143	WINCH HANDLE 6" STD.....2 SLC-6	
6A	33144	WINCH HANDLE 8" STD.....2 SLC-12, SLC-18, SLC-24 (shown) (vertical slot)	
6B	16343	WINCH HANDLE-O.A.LENGTH-8".....2 SLC-12, SLC-18, SLC-24 (parallel slot)	
7	6086	NUT,LP NYLOCK,1/2-13	
8	40458	RATCHET PAWL KIT.....1	
9	6190	CABLE KEEP.KIT (BRACKET TYPE)*.....1	
--	25625	NUT,HEX,10-24.....2	
--	80159	CARRIAGE BOLT.....2	
--	80160	KEEPER-CABLE (32525).....1	
--	80161	WASHER-STAR,INTERN,5/8"(32525).2	
10	6184	SPACER, DRUM BOLT, K-1550.....1	
11	31946	WINCH BRACKET, DRUM BOLT LOCK.....1	
12	6770	WINCH GEAR COVERS, K-1500.....1	
13	7256	SCREW,HHC,5/16-18 X 6 GRD.2	
14	6782	NUT,NYLOCK,5/16-18.....1	
15	6185	BOLT, DRUM SPACER.....1	
16	6034	NUT,HEX,JAM,1/2-13.....3	
17	7584	FRAME SPACER,K-1550.....1	
18	32890	SPACER,PINION SHAFT.....1	
19	7591	WINCH PINION PLATE, K-1550.....1	
20	6777	RATCHET GEAR,K-1550 1/2" I.D.....1	

401.1 Forks

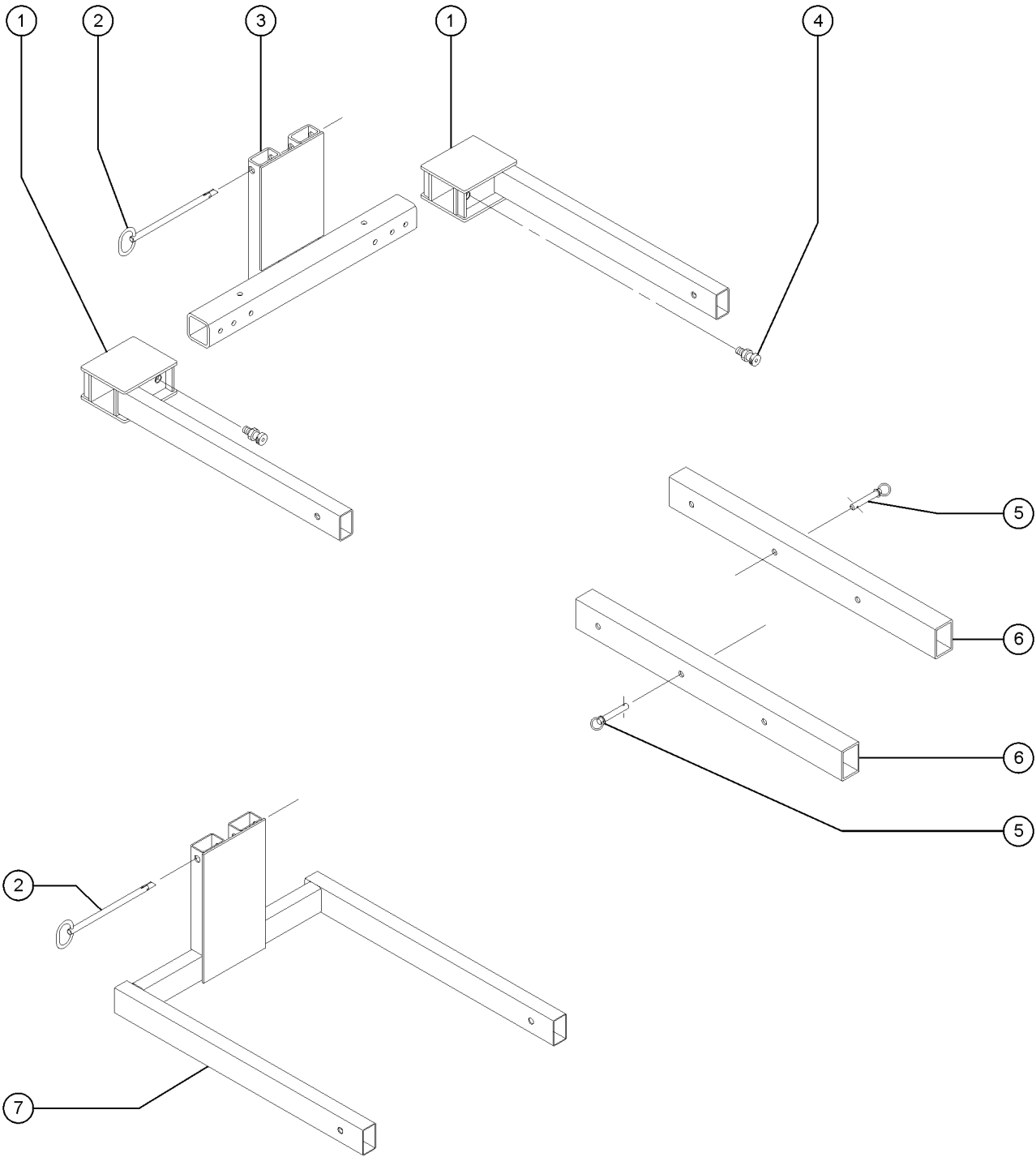

Item	Part No.	Description	Qty.
--	33543-S	SLC, ADJ FORK ASSEMBLY <i>includes items 1 - 4</i>	
1	33707-S	WELDMENT,ARM ADJ. FORK,"GRAY".....	2
2	48301	PIN,TOGGLE,.50 X 8.13***.....	2
3	35821	CARRIER - ADJ.FORK,-ST2.....	1
4	33674	PIN,LOCK,SHORT***.....	2
5	80679	PIN,BALL RET.-.5 X 2.7.....	2
6	33366-S	FORK EXTENSION, SINGLE***.....	2
7	33984	FORK,STD W/WORD DECALS SLC.....	1

402.1 Pipe Cradle, Load Platform and Boom Arm

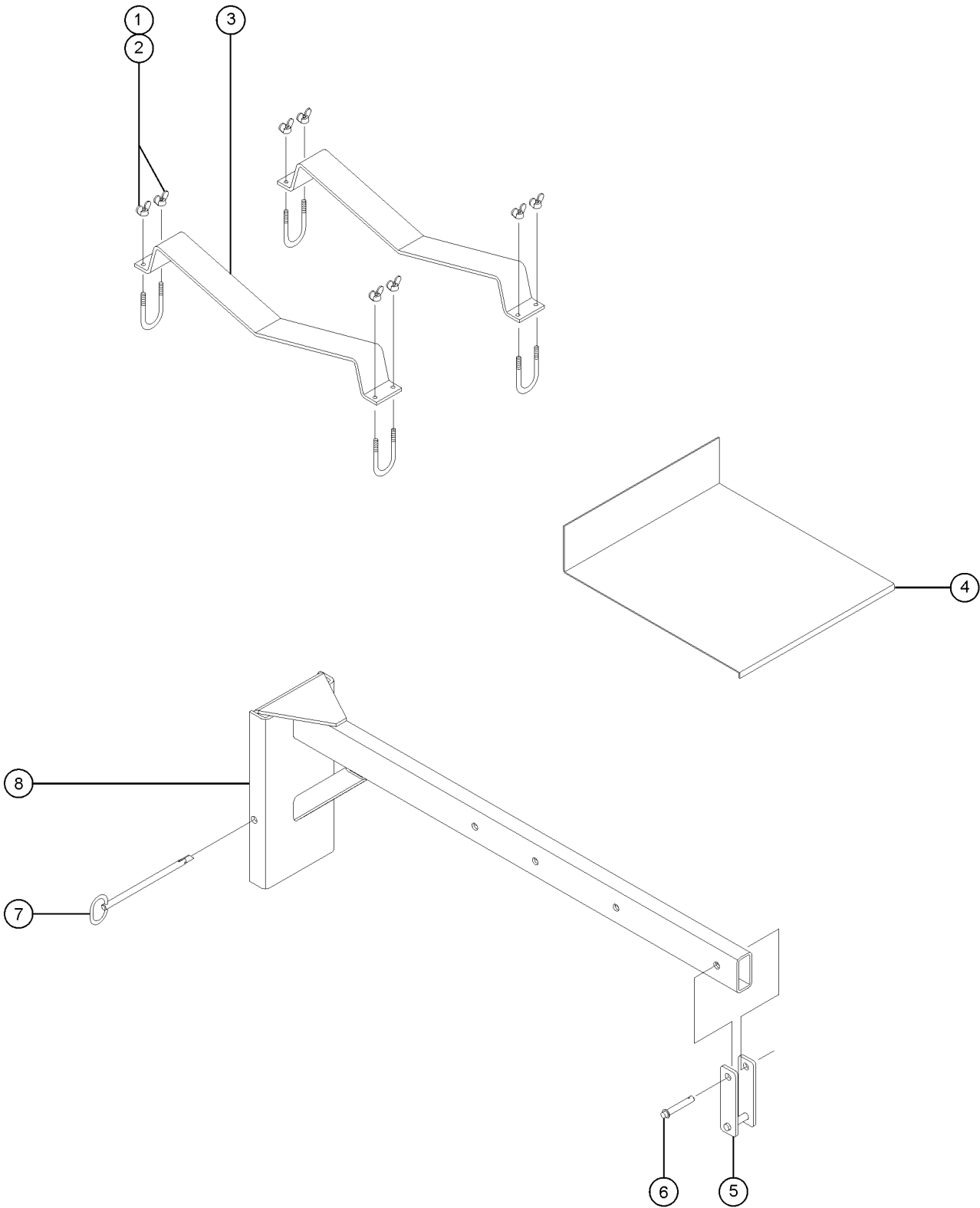

## 402.1 Pipe Cradle, Load Platform and Boom Arm

Item	Part No.	Description	Qty.
--	32569-S	SL/SLC PIPE HOLDER ACCESSORY <i>complete kit for first time installation</i>	
1	8170	NUT,WING,1/4-20.....	8
2	33045	U-BOLT,1/4-20 SL2 PIPE CRADLE	
3	80597	PIPE CRADLE, BLUE.....	2
4	35021	LOAD PLATFORM W/DECALS, SLC.....	1
5	32579-S	WELDMENT,CLEVIS STD. BOOM.....	1
--	5143	HOOK, " S "	
6	80679	PIN,BALL RET-.5 X 2.7.....	1
7	48301	PIN,TOGGLE,.50 X 8.13***.....	1
8	229447	SLC STD.BOOM ASSY/SERVICE/GRAY <i>gray; includes items 5, 6 and 7</i>	
8	32567-S	SLA/SLC STD.BOOM ASSY/SERVICE..... <i>blue; includes items 5, 6 and 7</i>	1

403.1 Rear Wheels

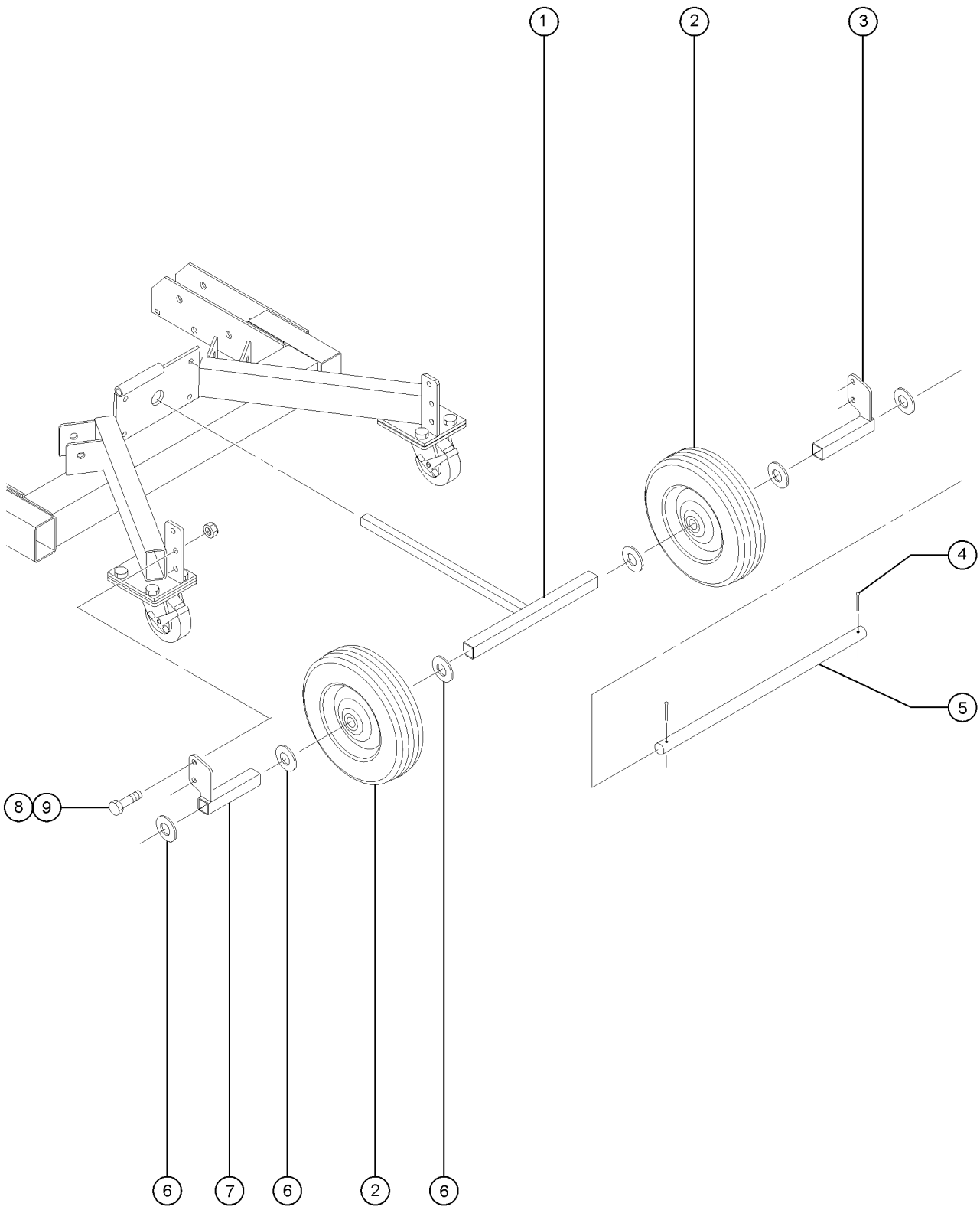

Item	Part No.	Description	Qty.
--	35848-S	SL REAR TRANSPORT WHEEL ASSY	
1	33831-S	WHEEL SPACER WELDMENT,SL"GRAY".....	1
2	35064	WHEEL,SOLID RUBBER,10X.75X2.75..... (to SN SLC07-39655)	2
3	33830-S	WHEEL SPACER MOUNT WELD,RH,SL.....	1
4	6094	PIN,COTTER,.125 X 1.....	2
5	57237	AXLE ROD, TRANSPORT WHEEL,SL.....	1
6	6564	WASHER,SHIM,.765X1.312 X.093**	
7	33829-S	WHEEL SPACER MNT WELD LH,SL.....	1
8	6019	SCREW,HHC,3/8-16 X 1.25 GRD 5	
9	4828	NUT,NYLOCK,3/8-16	

## Part Number Index

The Part Number Index is a numeric index of all part numbers included in this manual. The index shows what page(s) the part is used on.

Part Number	Page	Part Number	Page	Part Number	Page
100301	19	35005	27	6190	29
100309	17, 19	35015	17	6198	19, 21, 23-24, 27
10597	21, 27	35016	17	6199	29
10598	17	35017	17	6200	29
109579	19	35018	17	6326	19
109580	19	35019	17	6564	15, 19, 35
11337	17	35021	33	6587	19
11890	15	35064	15, 35	6600	19
11978	19	35101	24	6653	19
12016	15	35159-S	17	6732	17, 19
12343	19	35212	17	6770	29
12402	27	35213	17	6777	29
124790	19	35408	23-24	6782	29
13005	19	35442	23-24	7250	27
13066	21, 24	35443	23-24	7251	27
16343	29	35463	23-24	7256	29
21443	15	35814	19	7265	19
22788	27	35819	19	7571	29
229447	33	35821	31	7584	29
25625	29	35834	19	7590	29
31072	11	35848-S	35	7591	29
31822	19	37038	27	7713	23-24
31946	29	40153	23-24	80141-S	15
32470	27	40154	23-24	80142-S	15
32473	19, 21, 23-24	40155	23-24	80143-S	15
32474	19, 21, 23-24	40458	29	80144-S	15
32475	19, 21, 23-24	40513	11	80159	29
32476	27	4828	15, 17, 19, 24, 27, 35	80160	29
32483	27	48301	15, 31, 33	80161	29
32499	17	48373	11	80597	33
32509	17	49991	19	80679	31, 33
32519	17	49999	27	80987	21
32522	24	5143	33	8170	33
32524	17	5224	17	82487	13
32567-S	33	52675	11	8255	23-24, 27
32569-S	33	52701	27	82964	13
32576	17	52984	11, 13	8516	17
32577	17	52992	11, 13	90337	19
32579-S	33	52993	11, 13	97532	13
32687	11	52995	11, 13	97539	13
32714	11	5397	24	97541	13
32716	11	57016	21, 23-24	97543	13
32717	11	57018	24	97545	13
32770	11	57019	24	97546	13
32775	11	57021	24		
32883	17	57022	24		
32884	17	57023	24		
32885	11	57024	24		
32890	29	57028-S	27		
32891	29	57029-S	27		
32938	11	57031	27		
32939	11	57237	15, 35		
32945	29	57734	17		
33045	33	57735	15		
33143	29	57746	17		
33144	29	57782	17		
33366-S	31	57788	19		
33373	17	58094	17		
33385	19	58095	15		
33468	11	58750	15		
33539	19	6019	15, 19, 27, 35		
33540	19	6033	17		
33543-S	31	6034	17, 29		
33618	19	6052	21, 24, 27		
33658	15	6086	17, 21, 29		
33674	31	6091	19		
33700	27	6094	15, 35		
33707-S	31	6095	17, 19, 21, 23-24		
33811	21, 24	6097	17, 19		
33829-S	15, 35	6099	27		
33830-S	15, 35	6175	15, 17, 19, 24		
33831-S	15, 35	6184	29		
33843	19	6185	29		
33982	11				
33984	31				



October 2014

## Part Description Index

The Part Description Index is an alphabetical index of all part descriptions included in this manual. The index shows what page(s) the part is used on.

- A**
- ASSY,PIN & LANYARD\*\*\*.....17, 19  
 AXLE ROD, TRANSPORT WHEEL,SL.....15, 35  
 AXLE TUBE, SL2 LEG.....17
- B**
- BASE ASSY W/DECALS, SLC-12.....15  
 BASE ASSY W/DECALS, SLC-18.....15  
 BASE ASSY W/DECALS, SLC-24.....15  
 BASE ASSY W/DECALS,SLC-6.....15  
 BLOCK,END,DOWNSTOP.....24  
 BLOCK,PLUNGER,DOWNSTOP.....24  
 BOE LUBE.....19  
 BOLT, DRUM SPACER.....29  
 BOLT,SHOULDER,3/8-16 1.417 LNG.....24  
 BOLT-ROLLER,1/2-13X1.84 ZINC.....19, 21, 23-24  
 BRACKET, STAB.MOUNT,"GRAY".....17  
 BRAKE DISK,.5 BORE,K-1550.....29  
 BUMPER,RUBBER,DOWNSTOP.....24  
 BUSHING, SMALL PINION, FULTON.....29
- C**
- CABLE ASSEMBLY SL 408".....27  
 CABLE ASSEMBLY, SLC-6.....27  
 CABLE ASSY SL/ST 588" 3/16"\*\*\*.....27  
 CABLE ASSY SL/ST 756" 3/16"\*\*\*.....27  
 CABLE KEEP.KIT (BRACKET TYPE)\*.....29  
 CABLE REPLACEMENT COUPLER.....27  
 CAP,INSTRUCTION TUBE (RED).....19  
 CARRIAGE BOLT.....29  
 CARRIAGE,SL CONTRACTOR\*\*\*.....27  
 CARRIER - ADJ.FORK,-ST2.....31  
 CASTER,PL,SW,SB, 5 X 1.5\*\*\*.....15  
 CASTER,POST,SW,3.5X1.25,1/2-13.....17  
 CASTER,SL,SW, 4 X 1.5.....17  
 CLAMP TUBE,STABILIZER-"GRAY".....17  
 CLAMP,1.88,#30 X 1/4,RUB CUSH.....19  
 COLUMN#1,MACHINED,SLC SERV.....27  
 COLUMN#2,,MACHINED,SLC SERV.....27  
 COUPLER BAR ASSEMBLY,SLA&C,ST2...21, 24
- D**
- DECAL KIT, SAFETY/INST, SLC.....11  
 DECAL,2 SPD.WINCH SYMB.....13  
 DECAL,2 SPD.WINCH\*\*.....11  
 DECAL,CAUTION,DAMAGD MACHINE.....11  
 DECAL,CAUTION,MOVING PARTS SYM.....13  
 DECAL,COSMETIC,SLC-12.....11, 13  
 DECAL,COSMETIC,SLC-18.....11, 13  
 DECAL,COSMETIC,SLC-24.....11, 13  
 DECAL,COSMETIC,SLC-6.....11, 13  
 DECAL,CRUSHING HAZ/BRAKE LOCK.....11  
 DECAL,DANGER,ELEC.HAZ.....13  
 DECAL,GENIE SUPERLIFT CONTRACT...11, 13  
 DECAL,LABEL,OPER.MAN.STORAGE.....11  
 DECAL,LABEL,WINCH ONLY.....11  
 DECAL,LABEL,WINCH ONLY SYMB.....13  
 DECAL,NOTICE BOOM SETUP.....11  
 DECAL,SILENT WINCH.....11  
 DECAL,SYMBOL-READ THE MANUAL.....13
- DECAL,WARNING ADJ FORK SETUP.....11  
 DECAL,WARNING BOOM SAFETY.....11  
 DECAL,WARNING STD.FORK SAFETY.....11  
 DECAL,WARNING,BRAKE LOCK SYMB.....13  
 DECAL,WARNING,FALL HAZARD.....11  
 DECAL,WARNING,LOAD CHART SLC.....13  
 DECAL,WARNING,NO RIDERS.....11  
 DECAL,WARNING,NO RIDERS SYMB.....13  
 DECAL,WARNING/SAFETY-SLC.....11  
 DOWN STOP.....24
- E**
- E CLIP,.875 IN.SL LEG.....17
- F**
- FORK EXTENSION, SINGLE\*\*\*.....31  
 FORK,STD W/WORD DECALS SLC.....31  
 FRAME SPACER,K-1550.....29
- G**
- GLIDE BUTTON,SIDE,GLL,,100 TK.....15  
 GUARD,CABLE\*\*\*.....27  
 GUARD,ROLLER, SL2,.....19, 21, 23-24
- H**
- HANDLE GRIP, RUBBER .75 X 4.5.....19  
 HOLD DOWN KIT W/DECAL SL LONG.....15  
 HOLD DOWN KIT W/DECAL SL SHORT.....15  
 HOOK, " S ".....33
- I**
- INSTRUCT.TUBE W/CAPS-1.75 X 12.....19
- K**
- KEEPER-CABLE (32525).....29  
 KIT, CABLE ANCHOR BRK, SLC/ST\*.....21  
 KIT,CBL GRD,W/WRD DCALS,SLC.....19
- L**
- LATCH PLATE,STABILIZER SL2.....17  
 LOAD PLATFORM W/DECALS, SLC.....33  
 LOADING WHEEL ASSY ST/SL.....19  
 LOADING WHEEL WELD.W/DECAL SL2.....19
- M**
- MAST STIFFENER KIT.....19  
 MAST STIFFENER,LEFT,GRAY\*\*\*.....19  
 MAST STIFFENER,RIGHT,GRAY\*\*\*.....19
- N**
- NUT,HEX,10-24.....29  
 NUT,HEX,JAM,1/2-13.....17, 29  
 NUT,LP NYLOCK,1/2-13.....17, 21, 29  
 NUT,LP NYLOCK,3/8-16.....23-24  
 NUT,NYLOCK,1/2-13.....19, 21, 23-24, 27  
 NUT,NYLOCK,1/4-20.....19  
 NUT,NYLOCK,3/8-16.....15, 17, 19, 24, 27, 35  
 NUT,NYLOCK,5/16-18.....29  
 NUT,SQUARE 3/8-16 NC, PLATED.....23-24  
 NUT,WING,1/4-20.....33
- P**
- PIN,BALL RET.-.5 X 2.7.....31, 33  
 PIN,COTTER,,125 X .75.....15  
 PIN,COTTER,,125 X 1.....15, 35  
 PIN,LOCK,SHORT\*\*\*.....31  
 PIN,ROLL,,25 X .50.....27  
 PIN,ROLL,,25 X 1.25.....17  
 PIN,TOGGLE,,50 X 8.13\*\*\*.....15, 31, 33  
 PINION GEAR AND DISC K-1550.....29  
 PIPE CRADLE, BLUE.....33  
 PIVOT TUBE SL2 LEG.....17  
 PIVOT TUBE,STABILIZER.....17  
 PLATE,DOUBLER,DOWNSTOP.....24  
 PLATE,DOUBLER,SL MAST.....21, 23-24  
 PULLEY MOUNT , SL-2.....27  
 PULLEY MOUNT,#1 COLUMN,GRY,SLC.....27  
 PULLEY W/BEARING 4.65X.5 '98"\*.....27
- R**
- RATCHET GEAR,K-1550 1/2" I.D.....29  
 RATCHET PAWL KIT.....29  
 RETAINING RING.....29  
 RIVET,STEEL,P .25 X .375.....19  
 ROLLER KIT(SLA,SLC)-1EA.....23-24  
 ROLLER KIT(SLA,SLC)-20EA.....23-24  
 ROLLER KIT(SLA,SLC)-6EA.....23-24
- S**
- SAFETY BRAKE ASSY(SQ.NUT)SL2\*\*.....24  
 SCREW,FHS,3/8-16 X 1.5.....23-24  
 SCREW,HHC,1/2-13 X 1.25 GR5.....21, 27  
 SCREW,HHC,1/2-13 X 1.75.....27  
 SCREW,HHC,1/2-13 X 3.....17  
 SCREW,HHC,1/2-13 X 3.25.....17, 19  
 SCREW,HHC,1/2-13 X 6,GRD.8.....19  
 SCREW,HHC,1/4-20 X 3.....19  
 SCREW,HHC,3/8-16 X .75.....23-24, 27  
 SCREW,HHC,3/8-16 X 1.....15, 17, 19, 24  
 SCREW,HHC,3/8-16 X 1.25 GRD 5.....15, 19, 27, 35  
 SCREW,HHC,3/8-16 X 1.50,GR5.....17  
 SCREW,HHC,3/8-16 X 2.....17  
 SCREW,HHC,3/8-16 X 3.....19  
 SCREW,HHC,5/16-18 X 6 GRD.2.....29  
 SERIAL NUMBER PLATE, SL CONTR.....11  
 SHAFT,PINION (32891).....29  
 SHIM,,.75 X.45 X.064.....15  
 SHIM,SAFETY BRAKE, SLC.....23-24  
 SL REAR TRANSPORT WHEEL ASSY.....35  
 SL/SLC PIPE HOLDER ACCESSORY.....33  
 SLA/SLC STD.BOOM ASSY/SERVICE.....33  
 SLC STD.BOOM ASSY/SERVICE/GRAY.....33  
 SLC, ADJ FORK ASSEMBLY.....31  
 SLC, STABILIZER ASSY(SET)/SERV.....17  
 SPACER, DRUM BOLT, K-1550.....29  
 SPACER,MAST STIFFENER.....19  
 SPACER,PINION SHAFT.....29  
 SPRING,HOLDOWN SL2E.....15  
 SPRING,STABILIZER LATCH SL2.....17  
 STABILIZER STRUT,ASSY.....17  
 STRUT, LH, SL2.....17  
 STRUT, RH, SL2.....17

## Part Description Index (continued)

**T**

TUBE,DOWNSTOP.....24

**U**

U-BOLT,1/4-20 SL2 PIPE CRADLE.....33

UP STOP.....23-24

**V**

VIDEO,NTSC,SLA,CABLING PROCDR.....27

**W**

WASHER,FLAT,.5 HARDENED.....21, 24

WASHER,FLAT,.5X .125,HARDENED\*.....27

WASHER,FLAT,NYLON.515X.88X.093.....19

WASHER,FLAT,USS,1/2",Y.....17, 19, 21, 23-  
24

WASHER,FLAT,USS,3/8",Y.....17, 19

WASHER,FLAT,USS,5/16",Y.....24

WASHER,LOCK,0.5".....17

WASHER,PUSH ON .75 SHAFT.....19

WASHER,SHIM,.5 X .875 X .063.....21, 24, 27

WASHER,SHIM,.765X1.312 X.093\*\*.....15, 19,  
35

WASHER,SHIM,1.50 X .890 X .09.....17

WASHER-STAR,INTERN,5/8"(32525).....29

WELDMNT, LEG, SLC-12 GRAY.....17

WELDMNT, LEG, SLC-24 GRAY.....17

WELDMNT, LEG, SLC-6 GRAY.....17

WELDMNT, LOADING WHEEL AXLE.....19

WELDMNT, STABILIZER, SLC GRAY.....17

WELDMNT,ARM ADJ. FORK,"GRAY".....31

WELDMNT,CLEVIS STD. BOOM.....33

WELDMNT,LEG,SLC-18 GRAY\*\*\*.....17

WELDMNT,LOADING WHEEL,GRAY,SLC.....19

WHEEL SPACER MNT WELD LH,SL.....15, 35

WHEEL SPACER MOUNT WELD,RH,SL.....15,  
35

W H E E L                      S P A C E R

WELDMNT,SL"GRAY".....15, 35

WHEEL,POLY,6X2, 3/4\*\*.....19

WHEEL,POLYOLEFIN,2.5X1.25,7/8.....17

WHEEL,ROLLER,NYLATRON,1.75.....19, 21,  
23-24WHEEL,SOLID RUBBER,10X.75X2.75.....15,  
35

WINCH BRACKET, DRUM BOLT LOCK.....29

WINCH GEAR COVERS, K-1500.....29

WINCH HANDLE 6" STD.....29

WINCH HANDLE 8" STD.....29

WINCH HANDLE-O.A.LENGTH-8".....29

WINCH PINION PLATE, K-1550.....29

WINCH PLATE W/DECAL ST.....19

WINCH SPACER, 2 SPEED SLC,GRAY.....19

WINCH SPACER,1 SPEED SLC, GRAY.....19

WINCH,W/DECAL 1SPEED SL/ST.....29